



# EAGLE SERIES



**LITE, EAGLE, SILVER EAGLE**  
**90 degree notching**  
**from**

# Contents

<b>1</b>	<b>General comments .....</b>	<b>5</b>
1.1	Introduction .....	5
1.2	Transport of the machine .....	6
<b>2</b>	<b>Safety .....</b>	<b>7</b>
2.1	Work Safety Symbol .....	7
2.2	ATTENTION! Symbol .....	7
2.3	Location of the operating instructions .....	8
2.4	Instruction of the operating personnel .....	8
2.5	Updating of the operating instructions .....	8
2.6	Utilization of the operating instructions .....	8
2.7	Adherence to safety regulations .....	8
2.8	Attire .....	9
2.9	Signs .....	9
2.10	Changes in the machine .....	9
2.11	Spare parts .....	9
2.12	Emergencies .....	10
2.13	Fire extinguishers .....	10
2.14	Selection of personnel .....	11
2.15	Qualification of personnel .....	11
2.16	Assigned personnel .....	11
2.17	Electrical installations .....	11
2.18	Condition of the machine .....	12
2.19	Inspection of machine .....	12
2.20	Malfunctioning .....	12
2.21	Machine start-up .....	12
2.22	Electrical energy .....	13
2.23	Noise .....	13
<b>3</b>	<b>General comments .....</b>	<b>13</b>
3.1	Principles .....	13
3.2	Designated utilization .....	14
3.3	Sheet of Dimension Boschert Liteand Eagle .....	14
3.4	Technical data- Boschert Lite .....	15
3.5	Technical data- Boschert Eagle(LB-12) .....	16
3.6	Technical data- Boschert Silver with Cope (LB-13 KE).....	17
3.7	Boschert Technical Alert.....	18
<b>4</b>	<b>Operating elements .....</b>	<b>19</b>
4.1	Operating keys and pertaining LED's .....	20
4.2	Modes of operation .....	21

4.3	Starting the machine .....	22
4.4	Adjustment of cutting gap .....	23
4.5	Adjustment of stroke.....	23
<b>5</b>	<b>Installing new blades .....</b>	<b>21-22</b>
5.1	Changing blades and adjustment of blade clearance .....	21-22
<b>6</b>	<b>Maintenance .....</b>	<b>24-25</b>
6.1	Maintenance of the guiding cylinders LB 12 / LB 13 .....	24-25
6.2	Maintenance of the guiding system .....	26
	Amendment to 6.1.....	27
6.3	Lubrication of the hydraulic system (brief description) .....	28
6.4	How to change the oil and filter .....	29-30
<b>7</b>	<b>Hydraulic plan Boschert Lite, Eagle and Silver Eagle .....</b>	<b>31</b>
<b>8</b>	<b>Lite parts list: manufactured and purchased parts .....</b>	<b>32-41</b>
8.1	Boschert Lite manufactured parts.....	32-34
8.2	Boschert Lite purchased parts.....	35-36
8.3	Boschert Eagle manufactured parts.....	37-39
8.4	Boschert Eagle purchased parts.....	40-41
<b>9</b>	<b>Drawing Silver Eagle .....</b>	<b>42</b>
9.1	Front view of the machine .....	42
9.2	Section A - B .....	43
9.3	Section C - D .....	44
9.4	Disk spring column .....	45
9.5	Instructions for changing the ram return springs .....	45
<b>10</b>	<b>Electrical .....</b>	<b>46</b>
10.1	Changing machine voltage .....	46
10.2	Electrical plan USA .....	47
10.3	Electrical parts list USA.....	48
10.4	ACD Tableau USA .....	49
<b>11</b>	<b>Boschert technical alert .....</b>	<b>50</b>
<b>12</b>	<b>Spare parts .....</b>	<b>51</b>
12.1	Spare parts overview .....	51
12.2	Spare parts lists, spare parts graphics .....	51
12.3	Address for spare parts and after-sales service .....	51
12.4	Spare parts list .....	52
12.5	Features of the new patented horizontal hold down stop bar .....	53
12.6	Locking bolt Boschert LITE .....	54

12.7	Locking bolt Boschert EAGLE .....	55
12.8	Locking bolt Boschert SILVER EAGLE .....	56
12.9	Locking bolt parts list .....	57
12.10	Inside stop Boschert Lite, Eagle and Silver Eagle .....	58
12.11	Mini stop (optional) .....	59
12.12	Stroke adjustment Boschert Lite, Eagle and Silver Eagle .....	60
12.13	Hold down Boschert SILVER EAGLE .....	61

CINCINNATI PRECISION MACHINERY 513-860-4133

## 1 General comments

---

### 1.1 Introduction

---

These operating instructions will facilitate operation, maintenance and upkeep of the machine for the operator. They will assist in keeping the machine at a high level of performance during its long working life and contribute to accident prevention.

During maintenance and upkeep work on the machine, safety and accident prevention regulations must be observed.

The operating instructions for this machine are an integral part of the machine. All operators of the machine need to be familiar with them. In the event the machine is transferred to a different location or owner, the instructions should stay with the machine.

Prior to running the machine in production, make a trial run to ensure all components are functioning correctly and all operators are completely familiar with the correct and safe operation of the machine.

OSHA Statement: The end-user of the machine is completely responsible for safe guards.

CINCINNATI PRECISION MACHINERY 512-220-4133

## 1.2 Transport of the machine

When transporting the machine use only the eye bolt provided or equal. The bolt is an M20X standard eyebolt.

Using the lifting bolt will ensure proper balancing of the machine while moving it. Using other devices to move the machine could cause damage.



## 2 Safety

---

### 2.1 Safety Symbol

---

Within this manual, you will see the following symbol for all items relating to work safety which could constitute a danger. Pay particular attention to items in the manual with this symbol.

Ensure all machine operators are properly instructed in the safe operation of this machine.

In addition to any safety instructions in this manual, the end user of this machine is responsible for any and all guarding and proper use under OSHA and other regulations.



### 2.2 ATTENTION! Symbol

---

You will find this symbol in the manual where correct work procedures must be followed in order to avoid damage to the machine.

**ATTENTION !**

## 2.3 Location of the operating instructions

---

The operating instructions must always be accessible to the operator and maintenance personnel. Keep this manual in a safe place.

## 2.4 Instruction of the operating personnel

---

Observe all state and national safety regulations that may be supplementary to the operating instructions!

Such regulations may, for example, also concern handling of hazardous materials or the supply / wearing of personal protective gear.

## 2.5 Updating of the operating instructions

---

The operating instructions should be reviewed by all new personnel whenever new operators use the machine or it is moved from one department or company to another.

## 2.6 Utilization of the operating instructions

---

Personnel that have been designated to work at the machine must have read the operating instructions and, in particular, the chapter on safety instructions before starting to work. This is particularly applicable to personnel that only occasionally work at the machine, e.g. in set-up and maintenance work.



## 2.7 Adherence to safety regulations

---

It is management's responsibility to ensure all operators are using this machine in a safe and proper manner.





## 2.8 Attire

Personnel may not have exposed long hair or wear loose clothing or jewelry (including rings), as injuries may occur. Use personal protective gear when necessary or required by regulations.



## 2.9 Signs

Observe all instructions at the machine concerning safety and hazards. Always have complete instructions concerning safety at the machine!



## 2.10 Changes in the machine

In case of changes in the machine or its mode of operation which concern safety, turn machine off immediately and report the malfunction to the responsible person. Do not make any changes to the machine without approval of the supplier. This is also applicable to the installation and adjustment of safety equipment and valves as well as to the welding on bearing parts.

Arbitrary changes to the machines that modify anything delivered by BOSCHERT rule out the liability of the manufacturer for damages resulting from such actions.

***The warranty of the manufacturer becomes void under these circumstances.***



## 2.11 Spare parts

Spare parts must conform to the technical requirements stipulated by the manufacturer. This is always guaranteed by using original spare parts.

**ATTENTION!**

## 2.12 Emergencies

The machine has been adjusted to give its full cutting performance.

In an emergency the machine can be immediately cut off from electrical current by pressing the red emergency stop switch or by turning the main switch to 0.

The machine is equipped with hydraulic overload protection. If a sheet that is beyond the capacity of the machine is inadvertently loaded into the machine, the ram will stop mid-stroke (without damage to the machine.)

To reverse the ram, press the PROG button until the LED under SET UP is lit. Press the UP arrow key to move the ram out of the cut stroke.

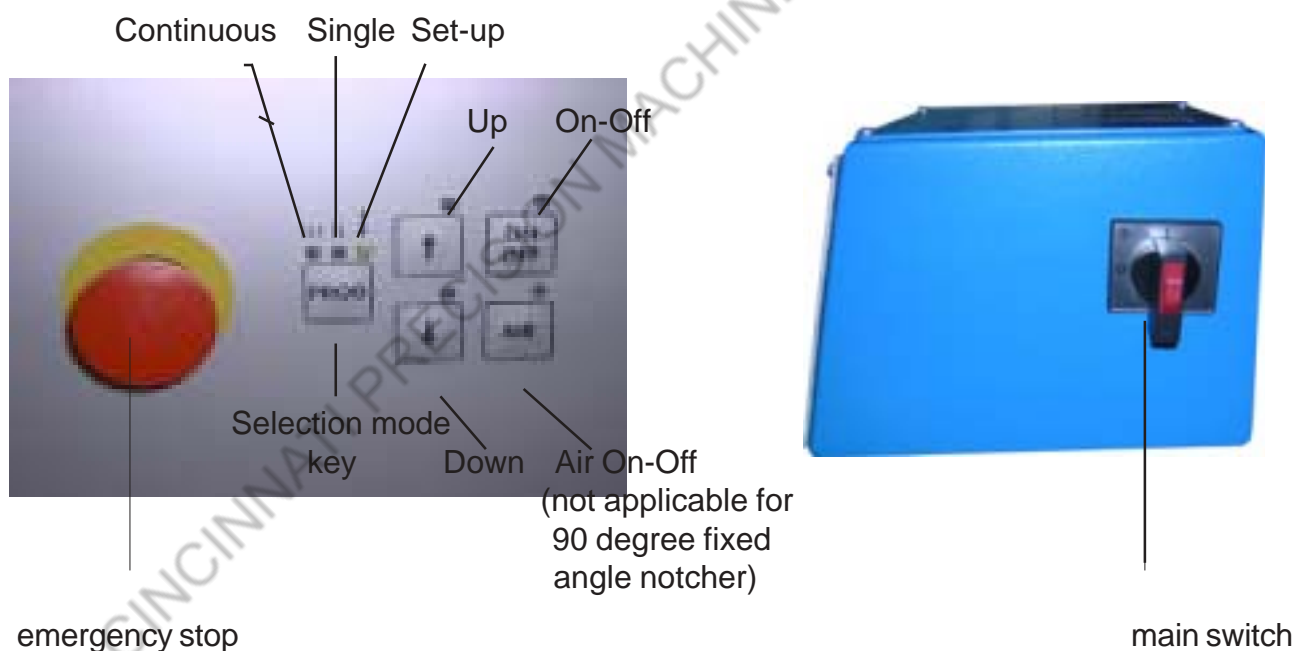

## 2.13 Fire Extinguishers

Be aware of the location and operation of fire extinguishers.



## 2.14 Selection of personnel

---

Work at the machine may only be implemented by dependable personnel. Observe legally permitted minimum age.



## 2.15 Qualification of personnel

---

Employ only trained or instructed personnel and clearly define the responsibilities of personnel concerning operation, set-up, maintenance and upkeep. Allow personnel being trained or introduced to work only at the machine under constant supervision of an experienced person.

**ATTENTION !**

## 2.16 Assigned personnel

---

Ensure that only assigned personnel work at the machine. All operators must follow all safety procedures. Do not allow operators to make any changes to the machine or procedures that may cause harm or damage.



## 2.17 Electrical installations

---

Work on the electrical components of the machine may only be done in accordance with local and state regulations. All electrical work must be done under the guidance and supervision of a licensed electrician.

**ATTENTION !**

## 2.18 Condition of the machine

---

### ATTENTION !

Take measures to ensure the machine is only operated in safe conditions. Operate machine only if all safety devices are available and functioning. Avoid all activities which are not safe.

**Never work without Plexiguard! Make sure the Plexiguard is fixed in place, especially after changing of the blades.**

## 2.19 Inspection of machine

---

### ATTENTION !

Inspect machine for damages and defects which can be externally recognized at least once during every shift! Report any changes which have occurred to the responsible person immediately. If required, shut down and secure machine immediately.

## 2.20 Malfunctioning

---

### ATTENTION !

Shut down and lockout machine immediately in case of malfunction. Repair or replace any malfunctioning components immediately.

## 2.21 Machine start-up

---

### ATTENTION !

Before the machine is started up after an extended time or after assembly and maintenance work, the operating personnel need to check all safety covers and safety installations to ensure they are in place and functioning. Before commissioning and starting up, see that no personnel could be endangered by the start of the machine.

## 2.22 Electrical energy

Use only original fuses with specified strength of current. In case of malfunctioning of the electric energy supply, switch off the machine immediately.

Work on the electrical component may only be done according to the applicable electrical codes by an electrician or an instructed person under the supervision of an electrician.



The electrical equipment of a machine is to be regularly inspected and examined. Deficiencies such as loose connections or scorched parts must be immediately repaired.

Check if power to the machine is cut off before inspection, maintenance, and repair work is carried out. First test whether the parts which have been cut off are free of voltage, then ground and short circuit them and isolate adjacent current-carrying parts.

If work is required on parts under power, have a second person available to operate the emergency shutdown or main switch in the case of an emergency. Isolate the working area with a red and white security chain and a sign of warning. Use only tools with proper insulation.

## 2.23 Noise

All sound protection installations of the machine must be in their protective position during operation. Wear necessary personal ear protection.

## 3 General comments

### 3.1 Principles

The machine has been built in accordance with current and recognized safety regulations. Nevertheless, careless use of this machine could result in injury.

This machine should be used only for purposes for which it was designed. All safety devices and guards must be kept in place and used at all times.

The end user of this machine has sole responsibility to provide proper safety devices and equipment to safeguard operators and to comply with all government and industry standards.

Any malfunctions which could impair safety must be reported immediately to supervisory personnel.

## 3.2 Designated utilization

The machine is exclusively designed for notching and/or punching. The manufacturer is not liable for damages resulting from such use. The risk is exclusively born by the user.

Observation of the operating instructions and adherence to inspection and maintenance conditions as well as ensuring the machine is used only for its designed purpose is the end-users responsibility.

\*Any other use of the machine may not be within the design parameters of the machine.

## 3.3 Sheet of dimension Boschert Lite and Eagle

Max. out of level floor 10 mm (0,4 inch)

Min. floor load 500 lb/sq. ft.

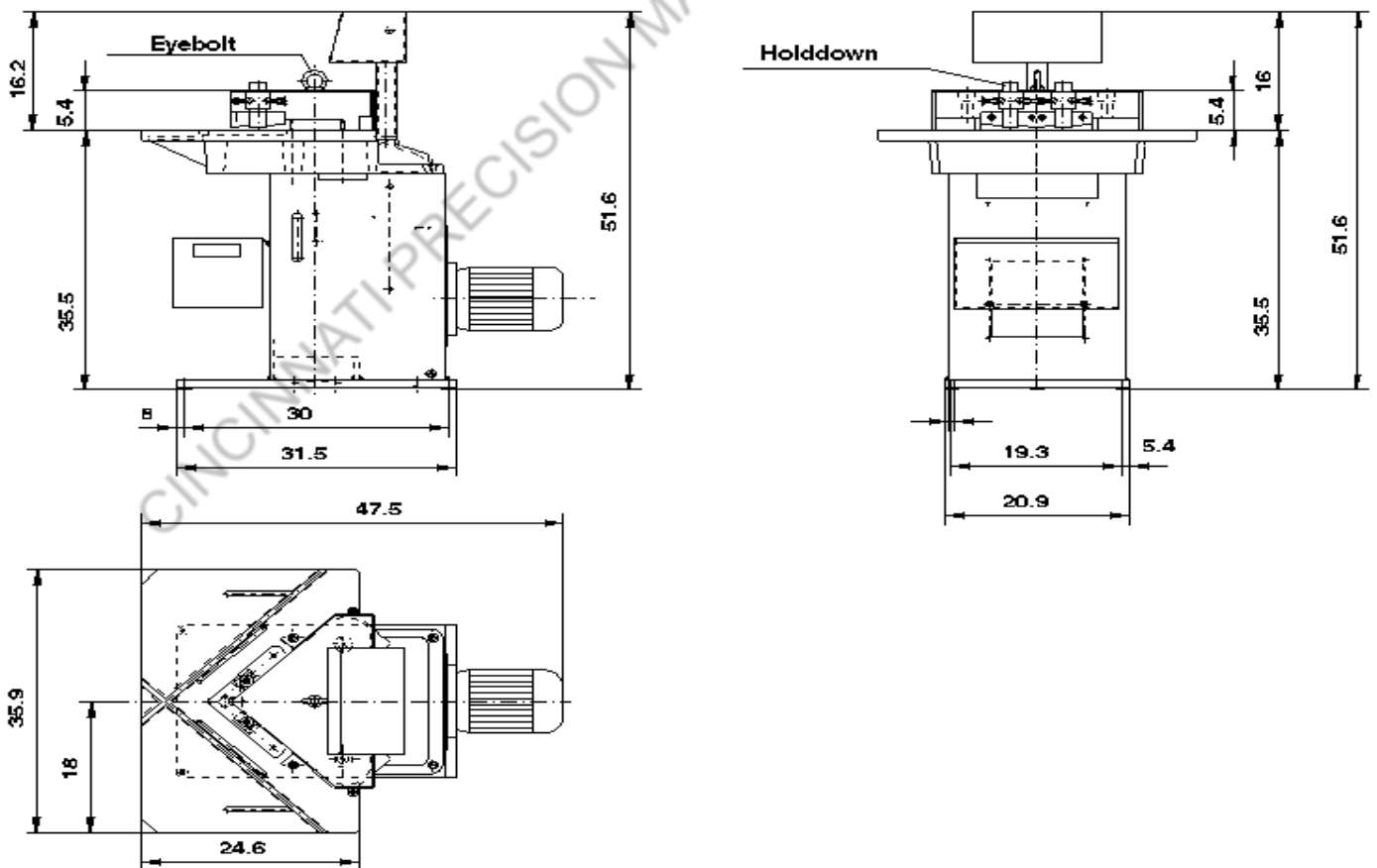

## 3.4 Technical data- Boschert Lite

Operating voltage	230	V	(US) or
	460	V	(US)
	575	V	(CDN)
Frequency	60	Hz	(US/CDN)
Control voltage	110	V	(US/CDN)
Nominal output of pump motor	4.5	HP	(US/CDN)
Weight	1450	Lbs.	
Length	50	inches.	
Width	36	inches.	
Total height	51	inches.	
Table height	35,5	inches.	
Max. notching capacity	5/32inch.	mild steel	
	10	ga stainless steel	
Max. length of cut	8-7/8" X 8-7/8",X90degrees		
Max. stroke	1.141"		
Max. number of strokes	40	strokes per minutes	

## 3.5 Technical data Boschert Eagle (LB-12)

Operating voltage	230	V	(US) or
	460	V	(US)
	575	V	(CDN)
Frequency	60	Hz	(US/CDN)
Control voltage	110	V	(US/CDN)
Nominal output of pump motor	6.5	HP	(US/CDN)
Weight	1600	Lbs.	
Length	52	inches.	
Width	44	inches.	
Total height	51	inches.	
Table height	35,5	inches.	
Max. notching capacity	1/4	inch. mild steel (50,000 psi)	
	3/16	inch. stainless steel (75,000 psi)	
Max. length of cut	8-7/8" X 8-7/8" X 90 degrees		
Max. stroke	1.141"		
Max. number of strokes	40	strokes per minutes	



## 3.6 Technical data Boschert Silver with Cope (LB-13 KE)

Operating voltage	230	V	(US) or
	460	V	(US)
	575	V	(CDN)
Frequency	60	Hz	(US/CDN)
Control voltage	110	V	(US/CDN)
Nominal output of pump motor	6.5	HP	(US/CDN)
Weight	2100	Lbs.	
Length	52	inches.	
Width	44	inches.	
Total height	51	inches.	
Table height	35,5	inches.	
Max. notching capacity	1/4		inch. mild steel (50,000 psi)
	3/16		inch. stainless steel (75,000 psi)
Max. length of cut	8-7/8" X 8-7/8" X 90 degrees		
Max. stroke	1.141"		
Max. number of strokes	40	strokes per minutes	

### 3.7 Boschert technical alert

---

Boschert's line of 90 degree fixed and 30-120 degree vari-angle notching machines are rated at:

- Mild steel= 50,000 psi
- Stainless steel= 65,000psi

Some customers are not able to notch to capacity using A-36, 1/4" structural sheets. A-36 has a tensile strength anywhere from 55,000 to 85,000 psi. TH2.3 Location of the operating instructions. This material is 10% to 60% over the rated capacity of mild steel on the machines.

If the initial cut of the A-36 is not continuous and steady, the tensile strength probably is harder than the machines rated capacity. (Example, first stroke stops and a second stroke is needed after restarting the machine.) Continued use in this situation can result in main piston fatigue and finally failure.

Note: Not all A-36 is created equal. Some will work fine and some will be over capacity. WE suggest you talk with your supplier about the sheets you are using.

## 4 Operating elements

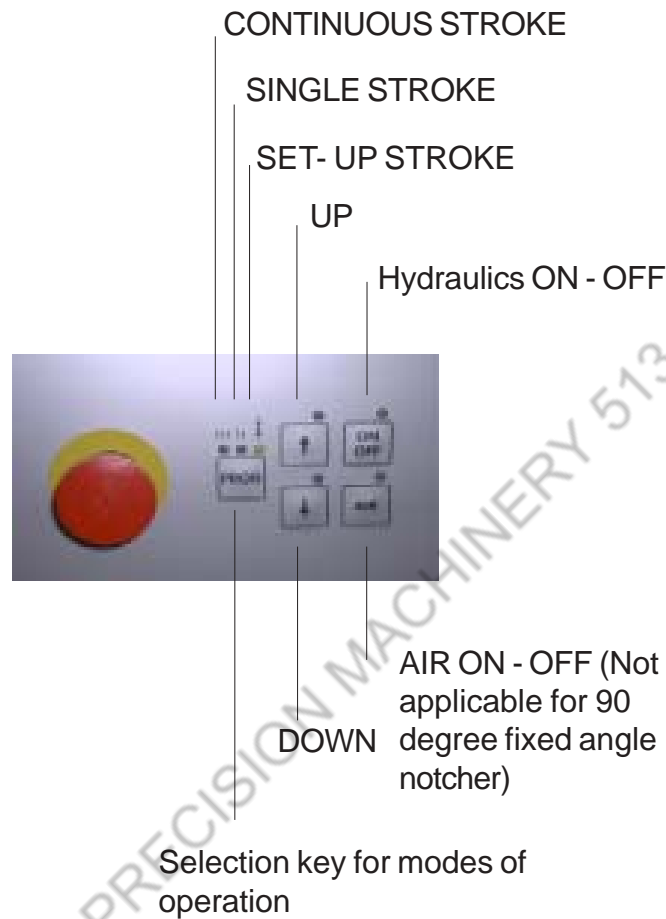

Foot switch

## 4.1 Operating keys and pertaining LED's

### 1) Key Hydraulics on (ON, OFF)

The hydraulic system can be activated by pressing this key (it is located on the top right-hand side of the operator panel). The hydraulic system may be turned off again by operating the same key.

The condition HYDRAULICS ON is indicated by the LED above the PROG key.

The hydraulic system is controlled by a high performance integrated circuit. If the hydraulic system is switched off during the operation, all outputs from this circuit to the hydraulic system are also stopped.

### 2) Key Pneumatics on (ON, OFF)

Not active on fixed angle machines.

The pneumatic system can be activated by pressing this key (it is located on the bottom right-hand side of the operator panel). The pneumatic system may be turned off again by operating the same key. The condition "Pneumatics on" is indicated by the LED above the key.

A high performance integrated circuit output "left" or "right" can only be accessed if the pneumatic system is switched on. If the pneumatic system is switched off via this key during a running movement, the tow high performance integrated circuit outputs accessed via the pneumatic system are also switched off by the software.

AIR functions only in machines with a pneumatic device.

## 4.2 Modes of operation

3 modes of operation can be set by LEDs:

**\*CONTINUOUS STROKE**

left LED



**\*SINGLE STROKE**

center LED



**\*SET-UP**

right LED



## Description



When switching on the control, the mode of operation SET-UP is always set first. The mode of operation can be changed according to the following diagram:

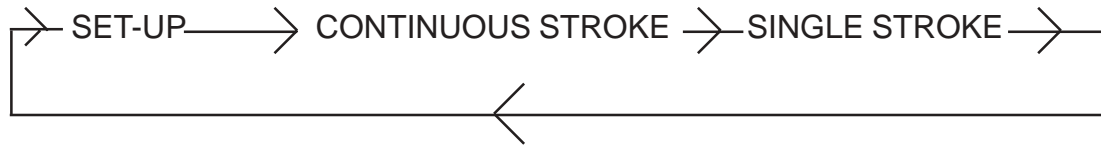

### SET-UP:

The machine can be moved to the lower limit by pressing the down arrow button on the operator panel. The LED above the button is illuminated if the machine is moving downwards. The machine can be moved to the upper limit by pressing the upwards arrow button on the operator panel. The LED above the key is illuminated if the machine is moving upwards.

### CONTINUOUS STROKE:

After the start via holding down the foot switch, the material is continually processed by complete downward and upward strokes until the foot is taken off the switch.

### SINGLE STROKE:

Only one complete downward and upward stroke can be done by pressing the foot switch. For a new start the foot has to be taken off the foot switch.

### 4.3 Starting the machine

---

1. Wire three hot wires to connector slots L1, L2, and L3 with the ground wire connecting into the PE slot.
2. Turn the main switch (located on the right side of the operator panel) vertically to the 1 position.
3. Press the ON-OFF button.
4. The direction of rotation of the motor fan must be the same as the arrow on the motor fan cover. If not, reverse two of the three incoming power wires.
5. If the motor is not visible the direction of the rotation can also be checked in a different manner:
  - Start motor by ON-OFF button
  - Adjust PROG button to Set-up stroke (see page 3.1)
  - Press UP or DOWN buttonNow the ram must move. If this is not the case, the poles of the motor must be changed.
6. If the motor does not start, check the voltage and press Bi-relay in control panel.
7. Set PROG button to Set-up stroke.
8. Tap on DOWN button or the footswitch. The ram including the top blades moves down by small increments until it reaches the lower limit switch.
9. Tap on UP button or footswitch. The ram moves upwards by small increments until it reaches the upper limits.

#### Single stroke Option

10. Set PROG button to Single stroke.
11. Press foot switch. The ram performs a complete single stroke and remains in the upper position.

#### Continuous stroke Option

12. Set PROG button to Continuous stroke.
13. Press foot switch down and keep it down. The ram performs continuous upwards and downwards movements.

## 4.4 Adjustment of cutting gap

---

The cutting gap between the top and bottom blades normally amounts to 0.003 inches (0.08mm). For the Lite model, the gap should be 0.002 inches (0.05mm).

New adjustment of the cutting gap is done as follows:

1. **Adjust main switch to 0 position (OFF).**
2. Place bottom blades into the table and align them with the rear stop area. Tighten cylinder screws slightly.
3. Tighten top blades firmly to ram.
4. Adjust main switch to 1 (ON).
5. Adjust PROG button to set-up.
6. Tap on DOWN button until the lowest position has been reached.
7. **Adjust main switch to 0 position (OFF).**
8. Adjust the desired cutting gap using a gauge, i.e. by moving the bottom blades against the top blades.
9. Tighten screws firmly.
10. Adjust main switch to 1 (ON).
11. Move ram upwards by pressing the UP button.

## 4.5 Adjustment of stroke

---

See section 12.12, page 60

# Installing new blades

## 5.1 Blade change and adjustment of blade clearance

1. Turn main switch to OFF position.
2. Remove plexiguard.
3. Open screws and take out the old blades.



### INFORMATION:

- Set blades = 1 right blade +1 left blade
  - Right blade is longer than left
  - When ordering machine blades please note machine model.
- On the lower blade are two socket head screws (M6 x 10 mm) to set the correct clearance.



### Clearance:

- Lite** = 0.05 mm (0.002 inch)  
**Eagle** = 0.08 mm (0.003 inch)  
**Silver Eagle** = 0.08 mm (0.003 inch)



4. Insert right top blade, tighten screws slightly.
5. Insert left top blade and move to the right blade, tighten screws slightly.
6. Open the screws on the right blade again and line up the two blades with a ruler.



On that position the screws are only **4/5**



## Installing new blades

7. Tighten screws on the top blades to 85 ft. lb f.( max. 122 Nm). Use a torque-wrench.
8. Turn the main switch to the ON position.
9. Set the function PROG to set-up stroke.
10. Move the ram by pressing the DOWN button to lower position.
11. Turn the main switch to the OFF position.
12. Insert the lower blades.
13. Use feeler gauge for correct clearance and fix the blades by using the adjustments screws (see picture).
14. Insert the screws.
15. Tighten screws on lower blades to 85 ft. lbs (122Nm).
16. Turn the main switch to the ON position.
17. Move the ram to the top by pressing the UP button.
18. Reattach the plexiguard.

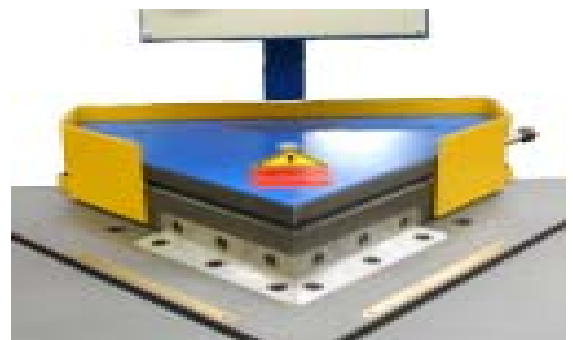

## 6.1 Maintenance of the guiding cylinders Boschert Lite, Eagle and Silver Eagle

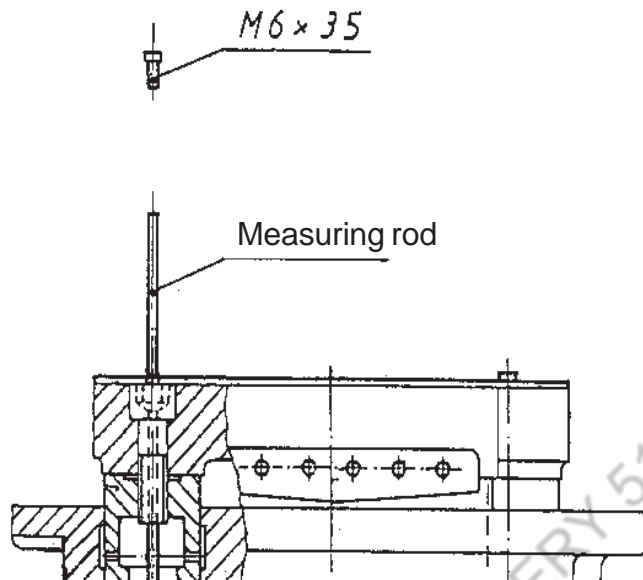

## 6.2 Maintenance of the guiding system

The machine has a lower as well as two upper guiding cylinders.

The two upper guiding cylinders are filled with 0.5 liter of the lubricating oil viscosity 46.

The oil level should be checked every 6 months.

### Examination of the two upper guiding cylinders:

Move ram into the topmost position.

Insert measuring rod into the screw (see picture) until it touches the bottom of the guiding bush.

Oil level must be between the two markings.

Possibly required additional filling can be done via the hole in the screw.

### The lower guiding cylinder:

The lower guiding cylinder is maintenance-free and does not have to be lubricated.

### Boschert Notcher Top Cylinder Oil Measuring Rod Specifications

If measuring rod shipped with machine is lost, one can easily be made to the following specifications.

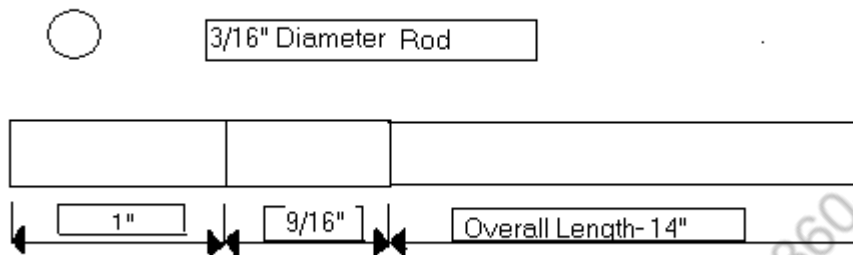

The two upper cylinders are filled with 0.5 liter of Shell Tellus 933 or equal oil.

The oil level should be checked every six months.

1. Move the ram to the topmost position
2. Remove the M6x35mm screw from the top of the pentagon shaped cover.
3. Insert the measuring rod into the hole (through the cylinder retaining bolt). The oil level should be between the two marks on the measuring rod.
4. If not, add oil, making sure not to overfill.
5. Replace the M6 set screw.

## 6.3 Lubrication of the hydraulic system (brief description)

---

### Maintenance

The oil container of the machine contains 25 l of hydraulic oil which serves the hydraulic systems and the lubrication of the lower guiding cylinder.

### Type of Oil

The supplied oil in the hydraulic is H-LP 46. Viscosity 46 or equivalent oil of other manufacturers may also be used.

### Change of Oil

The hydraulic oil needs to be changed after approx. 3000 hours of operation.

### Lubrication of Blades

Add lubricating oil drop by drop. In the case of steel sheets, lubricate with oil. In the case of aluminium sheets lubricate with oil or petroleum. Process plastic material in a dry fashion.

CINCINNATI PRECISION MACHINERY 513-8604133

## 6.4 How to change the oil and filter

Remove all the bolts holding the square motor mounting plate. (page one) Being careful to support the back of the motor. You will need to pry the plate away from the base because of silicone sealant between the two. Carefully tilt the motor and the hydraulic unit down and to the rear. Caution is to be taken to watch for the electrical hook-ups going to the valve and the main hydraulic hose going to the bottom piston.. Remove them if necessary and rest the motor on the floor.

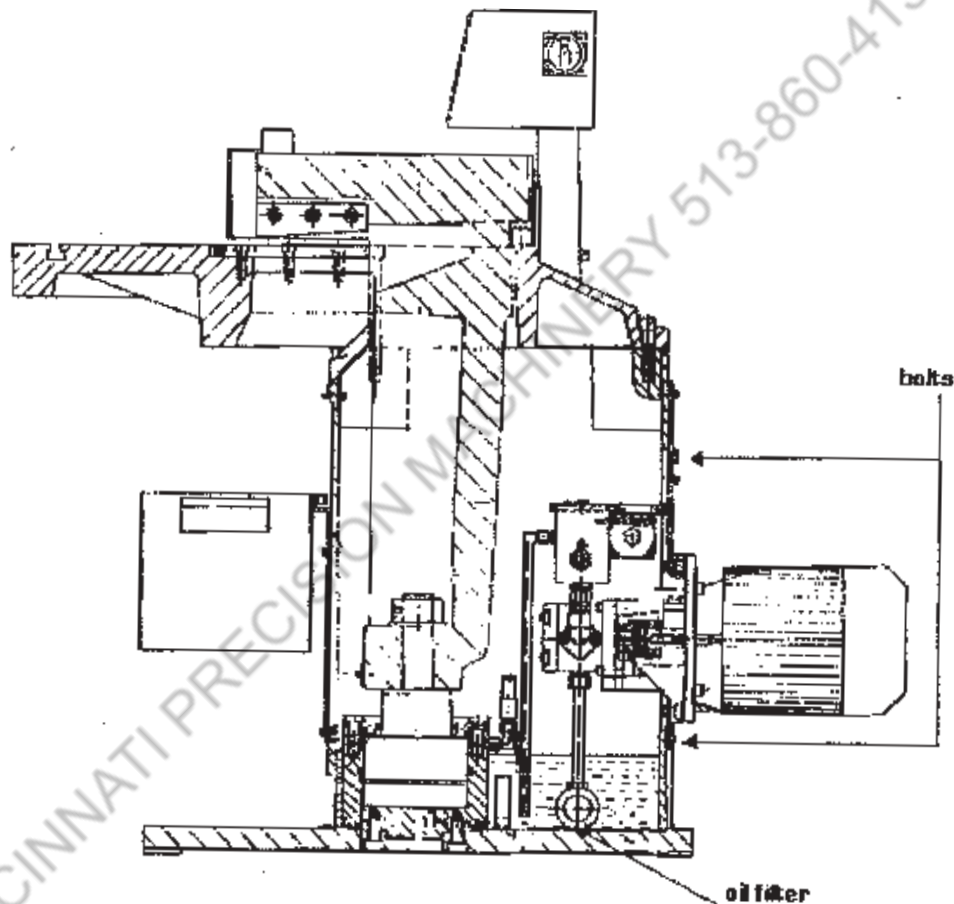

Remove the old oil and clean the bottom of the tank. Refill the tank with equivalent non-foaming hydraulic oil to a level of 4.5" deep.

The oil filter can be removed and cleaned by soaking in a non-combustible cleaning solution and blowing clean. Caution must be taken and all safety measures used including eye protection.

Or you can replace the filter with part number 1579

Replace the hook-ups (if you removed them) and bolt the hydraulic assembly back in place using a silicone based sealant.

## 6.4 How to change the oil and filter

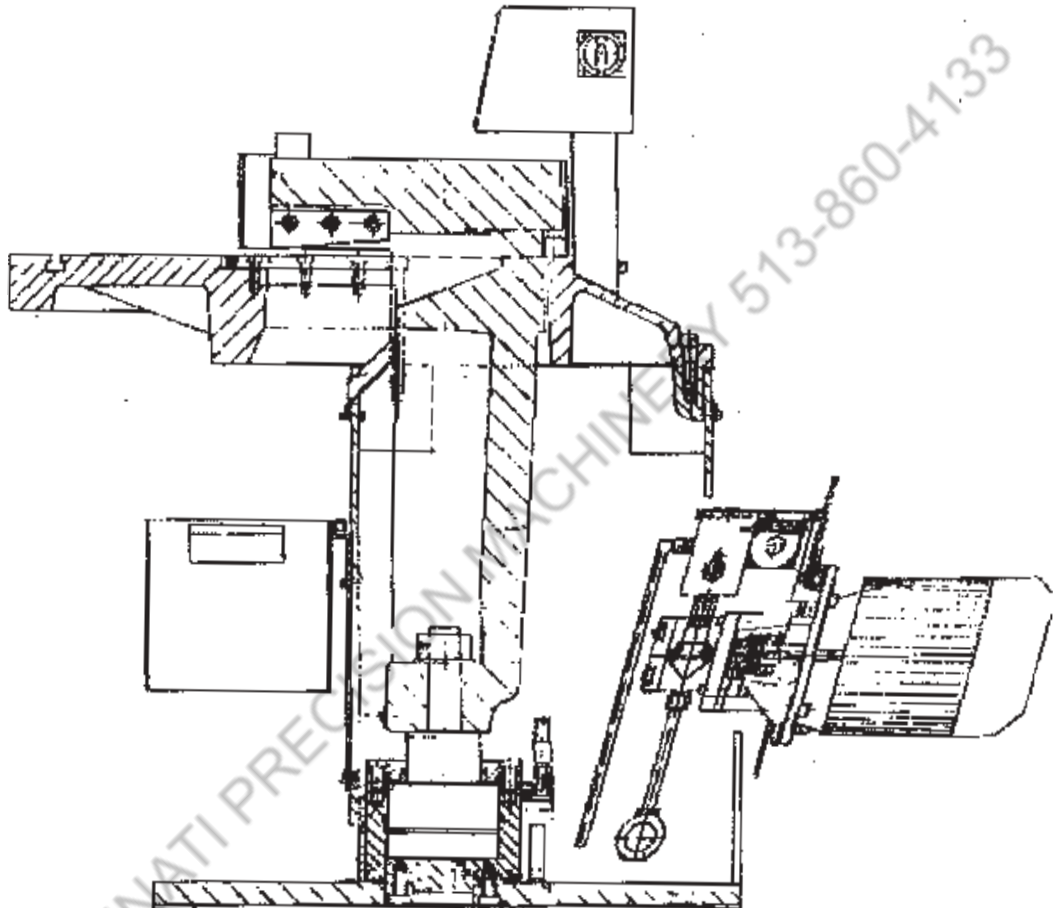

## 7 Hydraulic plan Boschert Lite, Eagle and Silver Eagle

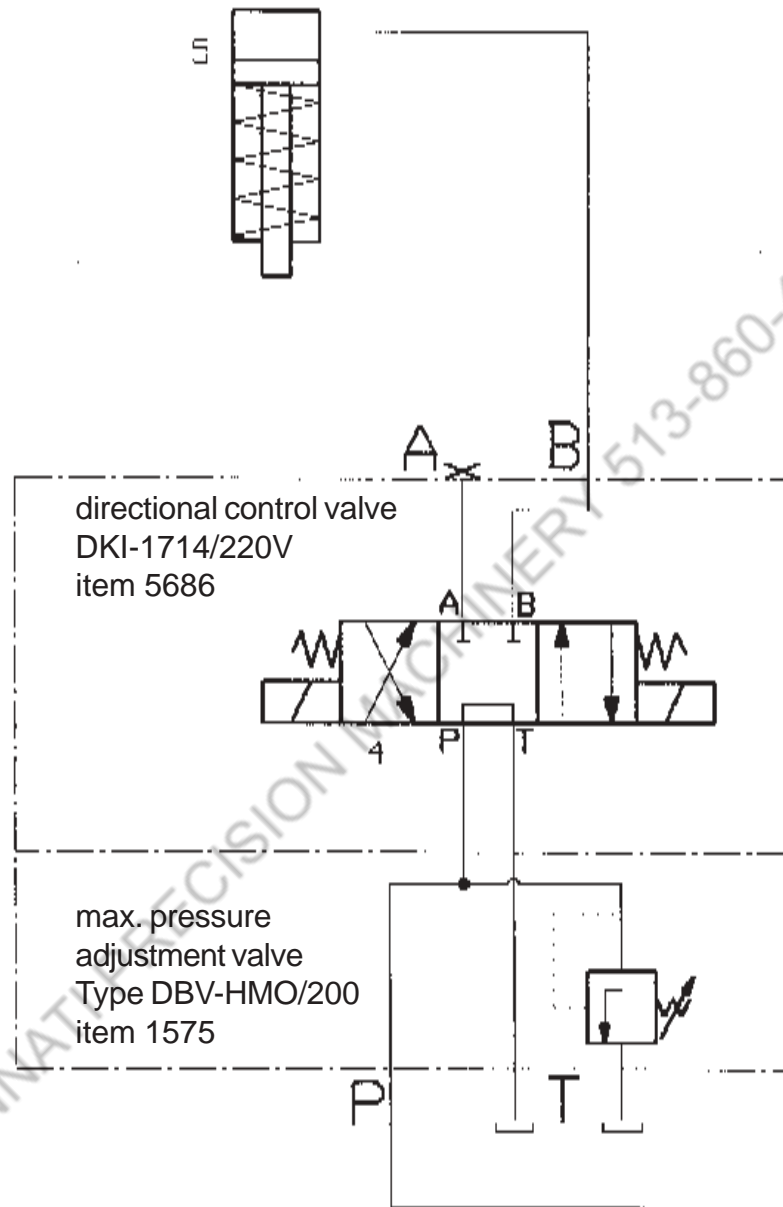

- 1 = rotary current motor                      4 kW      1500 rev/min
- 2 = gear pump                                      17 l/min
- 3 = suction filter                                 23 l/min
- 4 = 5/3 directional control valve
- 5 = hydraulic cylinder + lower guiding cylinder

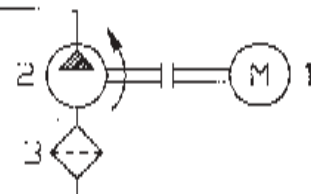

## 8.1 Boschert Lite manufactured parts

item	Description	qns.	format of drawing	remarks
1300	Summary		A0	
1004	Table board	1	A1	Model No.:TB12 1 1700
1304	Frame	1	A0	
1306	Ram	1	A0	Model No.:LB15/2 800
1404	Distributor block	1	A2	
1309	Hydraulic cylinder	1	A4	
1312	Hydraulic piston	1	A2	
1313	Cylinder lid	1	A2	top of Hydraulic system
814	Bolt	2	A4	
1014	Guiding piston	2	A3	inductively hardened
1015	Cover disk	2	A4	
1316	Angle 1/2 disk spring	2	A4	GG40 Model No.:110
819	Spring guide bolt	2	A4	
821	Angle	1	A4	for Final switch
1317	Support plate	1	A4	for stroke adjustment
2040	Final switch cam	2	A4	
2041	U profile	1	A4	for stroke adjustment
5053	Guiding nut	2	A4	
1024	Bottom blades - set	1	A2	2 pieces each
1025	Top blade - set 4'	1	A2	
1848	Top blade - set 5'	1	A2	TB12 /6mm /TB13
1789	Stripper guide bush	2(4)	A3	6mm GG40 Mod.-No.:LB15/3 (LB12/6 /LB13)
1790	Stripper guide ram	2(4)	A4	6mm hardened (TB12/6 /TB13)
1791	Sliding block	2(4)	A4	6mm for Stripper guide (TB12/6 /TB13)
1016	Cover sheet	1	A4	
840	Cover sheet	1	A3	



## 8.1 Boschert Lite manufactured parts

item	description	pos.	format of drawing	remarks
1029	Cover sheet	1	A4	top
1030	Waste slide	1	A3	
1026	Waste container	1	A2	
1032	Protection	1	A4	bottom for waste
848	Oil pipe	2		d=10 x 1,5 x 400 Ermeto
849	Oil pipe	1		d=10 x 1,5 x 180 Ermeto
1078	Protection	1	A3	
1078/1	Protection	1	A3	
1041	Cover sheet	1	A4	on room
1050	Flexi protection	1	A2	with stripper guide (TR12/6 /TR13)
1051	Flexi protection	1	A2	without stripper guide
1043	Power housing	1	A3	
1044	Panel	1	A3	
1045	Cover sheet	1	A4	
1029	Scale rod right	1	A4	
1030	Scale rod left	1	A4	
1031/1	Scale rod right	1	A4	
1032/1	Scale rod left	1	A4	
1086	Scale rod left	1	A3	0-18cm
1087	Scale rod right	1	A3	0-18cm
15155	Inside stop 405		A3	
15147	Shaft 405 non-gradure	1	A3	f. inside stop
15138	Terminal piece	1	A4	f. inside stop
15139	Disk	1	A4	f. inside stop
15223	Retention stop	2		
15225	Scale disk	2	A3	f. retention stop
15226	Stop strip	2		
15227	Stop strip	2		

## 8.1 Boschert Lite manufactured parts

item	description	pos.	format of drawing	remarks
15220	Stop strip	2	A3	
15230	Sliding block 125	2	A3	1. retention stop
15231	Threaded bolt	2	A4	2. retention stop
15232	Retaining bolt	2	A4	3. retention stop
15233	Knurled disk	2	A4	4. retention stop

CINCINNATI PRECISION MACHINERY 513-860-4133

## 8.2 Boschert Lite purchased parts

item	description	qty.	remarks
890	Pump support	1	LDL 210 199 Fa.Kahmer+Jansen
1574	Gear pump	1	DEG 211 Fa.ATOS
1575	Max. pressure ad.val.	1	DLV-Palzone 1100/300 Fa.ATOS
1576	Coupling	1	
1579	Section filler	1	3/4"
1580	Direct. control valve	1	DKF 1714/8 Fa.ATOS
1583	SVGE-15 PDR RD	3	Fa.Emeto
1584	WR 15 PDR	1	Fa.Emeto
1585	UL-3/4" x 1/2"	1	Fa.Emeto
1591	Plug	1	con. gal 1/8" Fa.Emeto
1592	GE-15-PLK	3	Fa.Emeto
1593	EVW-15-PT	1	Fa.Emeto
1594	XOK-15/10 PL	1	Fa.Emeto
1596	GE-10-PLK	3	Fa.Emeto
1597	EVW-10-PL	4	Fa.Emeto
1599	Circular seal ring	2	20 x 2
1601	WST 1/4"	1	Fa.Emeto
901	SP flange	2	WFG - 1/2" x 40
905	High pressure hose	1	d 10 x 600 Fa.Busch
1385	PO-30-140-1000 Stadi	1	150x155,1x6,3 Fa.HMF
1386	O-ring 148,13 x 4,34	1	NBR 70 Shore A Fa.HMF
1387	PO-30-140-1000 Stadi	1	100x115,1x6,3 Fa.HMF
1388	O-ring 107,32 x 4,33	1	NBR 70 Shore Fa.HMF
1391	O-ring 170 x 4	1	NBR 70 shore A
1392	O-ring 162 x 4	1	NBR 70 Shore A
1047	O-ring 93 x 3	2	NBR 70 Shore A
1397	Cylinder screw	10	DIN6912 M16x35 10.9 1. hydr. cylinder

## 8.2 Boschert Lite purchased parts

item	description	qty.	remarks
1053	Cylinder screw	2	DIN912 M30x90 12.9 f. rem
1099	Hexagon nut	1	DIN934 M42 8.8 f. piston
1632	Disk spring	120	d=60x20,5x2,5 f. return stroke Fa. Mabea
930	Limit switch	2	TC BT 12 48 Fa. Schönbeck Electronic
2195	Pressure spring	2	VD 145 F Fa. Gutekunst
1412	Terminal box	1	GEH.KPL.CA 160 Fa. Beckstein
1570	AC motor	1	50Hz 380V-4kW
57871	AC motor	1	50Hz 415V-4kW
57872	AC motor	1	60Hz 220/440V-4,0kW
57873	AC motor	1	60Hz 575V-4,8kW
15141	Adjustable handle	1	GN6337 3 70 M8 35 N Fa. Ganter
15205	Adjustable handle	2	GN99.2-20-M12-N Fa. Ganter
15237	Pressure spring	2	B 192 1,2x11,20x29,4 Fa. Gutekunst
1523	Disk spring f. stripper	50	D=34xØ=12,5x1,0 Fa. Gutekunst (LD12/6/LB13)

CINCINNATI PRECISION MACHINERY 513-860-4133

## 8.3 Boschert Eagle manufactured parts

item	description	pcs.	format of drawing	remarks
1300	Summary		A0	
1004	Table board	1	A1	Model No.:LB12-1-1100
1301	Table board	1	A1	Model No.:LB12-1-1100
1302	Stop table	1	A0	Model No.:LB1302 D
1304	Frame	1	A0	
1306	Ram	1	A0	Model No.:LB15/2-800
1505	Distributor block	1	A2	
1309	Hydraulic cylinder	1	A3	
1312	Hydraulic piston	1	A2	
1313	Cylinder lid	1	A3	top f. Hydraulic system
814	Bolt	2	A4	
1014	Guiding piston	2	A3	inductively hardened
1015	Cover disk	2	A4	
1316	Angle f.disk spring	2	A4	GGG40 Model No.:10
819	Spring guide bolt	2	A4	
821	Angle	1	A4	for Final switch
1317	Support plate	1	A4	for stroke adjustment
2040	Final switch cam	2	A4	
2041	U-profile	1	A4	for stroke adjustment
5053	Guiding nut	2	A4	
1024	Bottom blades - set	1	A2	2 pieces each
1848	Top blade - set 5°	1	A2	LB12 /6mm /LB13
1789	Stripper guide bush	2(4)	A3	6mm GGG40 Mod.-No.:LB15/8 (LB12/6 /LB13)
1790	Stripper guide ram	2(4)	A4	6mm hardened (LB12/6 /LB13)
1791	Sliding block	2(4)	A4	6mm for Striper guide (LB12/6 /LB13)
1016	Cover sheet	1	A4	

## 8.3 Boschert Eagle manufactured parts

item	Description	pos.	format of drawing	remarks
040	Cover sheet	1	A4	
1329	Cover sheet	1	A4	top
1400	Waste slide	1	A3	
1026	Waste container	-	A2	
1333	Protection	-	A4	bottom for waste
040	Oil pipe	3		d=10 x 1,5 x 400 Ermeto
849	Oil pipe	1		d=15 x 1,5 x 185 Ermeto
1336	Protection left	1	A3	without stripper guide
1337	Protection right	1	A3	without stripper guide
1338	Protection left	1	A3	with stripper guide
1339	Protection right	1	A3	with stripper guide
1340	Protection rear	1	A3	
1341	Cover sheet	1	A3	on rear
1550	Flexi protection	1	A2	with stripper guide (TR12/5 / TR13)
1513	Flexi protection	1	A2	without stripper guide
1343	Power housing	1	A3	
1344	Panel	1	A3	
1345	Cover sheet	1	A4	
1078/1	Strip	2	A4	left in notching extension
1084	Scale rod left	1	A3	parallel to bottom blades C-67cm
1085	Scale rod right	1	A3	parallel to bottom blades C-67cm
1086	Scale rod left	-	A3	0-18cm
1087	Scale rod right	-	A3	0-18cm
1088	Scale rod front	-	A3	46cm-0 46cm
1089/1	Scale rod left	-	A3	0-18cm / 0-7 inch
1090/1	Scale rod right	-	A3	0 18cm / 0 7 inch
1091/1	Scale rod front	-	A3	46 0 46cm / 18 0 18 inch
1092/1	Scale rod left	-	A3	" 0 67cm / 0 26 inch

## 8.3 Boschert Eagle manufactured parts

Item	Description	pos.	Format of drawing	Remarks
1093/1	Scale rod right	1	A4	- " - 0-67cm / 0-26 inch
15000	Mini stop		A3	
15002	Sliding block	2	A3	f. mini stop
15004	Stop belt	2	A3	f. mini stop hardened
15135	Inside stop 485		A3	
15137	Shaft 485 mm-groove	1	A3	f. inside stop
15138	Terminal piece	1	A4	f. inside stop
15139	Disk	1	A4	f. inside stop
15171/1	Stop strip	1	A4	500 mm f. retention stop
15171/2	Stop strip	1	A4	500 mm f. retention stop
15225	Scale disk	2	A3	f. retention stop
15230	Sliding block 125	2	A3	f. retention stop
15231	Threaded bolt	2	A4	f. retention stop
15232	Retaining bolt	2	A4	f. retention stop
15244	Knurled disk	2	A4	f. retention stop

## 8.4 Boschert Eagle purchased parts

Item	Description	pos.	Remarks
890	Pump support	1	D6D 210 199 Pa.Rabmer+Lansen
1574	Gear pump	1	PPS 211 Pa.ATOS
1575	Max. pressure ad.val.	1	DBV-Patrons HMO/JOU Pa.ATOS
1576	Coupling	1	
1579	Suction filter	1	1/4"
1580	Direct control valve	1	DKT-1/14/8 Pa.ATOS
1583	EVGE 15 PLR ED	2	Pa.Emeto
1584	WE-15-PLR	1	Pa.Emeto
1585	RT-3/4" x 1/2"	1	Pa.Emeto
1591	Plug	1	conical 1/8" Pa.Emeto
1592	GF-15-PLR	3	Pa.Emeto
1593	RVW 15 PL	1	Pa.Emeto
1594	KOR 15/10 PL	1	Pa.Emeto
1596	GF-10 PTR	3	Pa.Emeto
1597	RVW 10 PL	4	Pa.Emeto
1599	Circular seal ring	2	20 x 2
1601	VSTT R 1/4"	1	Pa.Emeto
901	SF flange	2	WFG - 1/2" x 40
905	High pressure hose	1	d=10 x 600 Pa.Busch
1365	PC-30-140-1500 Stadi	1	150x165,1x6,3 Pa.HME
1366	O-ring 150,12 x 5,34	1	NBR 70 Shore A Pa.HME
1387	PC-30-140-1600 Stadi	1	100x115,1x6,3 Pa.HVF
1388	O-ring 107,32 x 4,33	1	NBR 70 Shore Pa.HME
1391	O-ring 170 x 4	1	NBR 70 Shore A
1392	O ring 142 x 4	1	NBR 70 Shore A
1047	O ring 93 x 3	2	NBR 70 Shore A
1397	Cylinder screw	16	DIN912 M16x35 10.9 f.hydr.cylinder



## 8.4 Boschert Eagle purchased parts

item	description	pos.	remarks
1053	Cylinder screw	2	DIN912 M30x90 12.9 F. ren
1399	Hexagon nut	1	DTN934 M42 8.8 F. piston
1632	Disk spring	130	d=60x20,5x2,5 1.921000 81,000 Pa.Mubea
270	Limit switch	2	IG BT 12 48 Pa.Schönbuck Electronic
2195	Pressure spring	2	VD 14x F Pa.Gutekunst
1417	Terminal box	1	GEH. 3PT. CA 160 Pa.Bergstein
1578	AC motor	1	50Hz 380V 4kW
1578/1	AC motor	1	50Hz 415V 4kw
1578/2	AC motor	1	60Hz 220/240V-4,8kw
1578/3	AC motor	1	60Hz 375V 4,8kw
15006	Pressure spring	2	D 103 0,63x5,63x10,5 Pa.Gutekunst
15141	Adjustable handle	1	CNE 32.1-20-M8-N Pa.Ganter
15205	Adjustable handle	2	CNE 9.2-20-M12-N Pa.Ganter
16237	Pressure spring	2	D 192 1,20x11,20x29,5 Pa.Gutekunst
1828	Disk spring (stripper)	50	D 140d 12,5x1,0 Pa.Gutekunst (0312/672013)

## 9 Drawing Silver Eagle

### 9.1 Front view of the machine

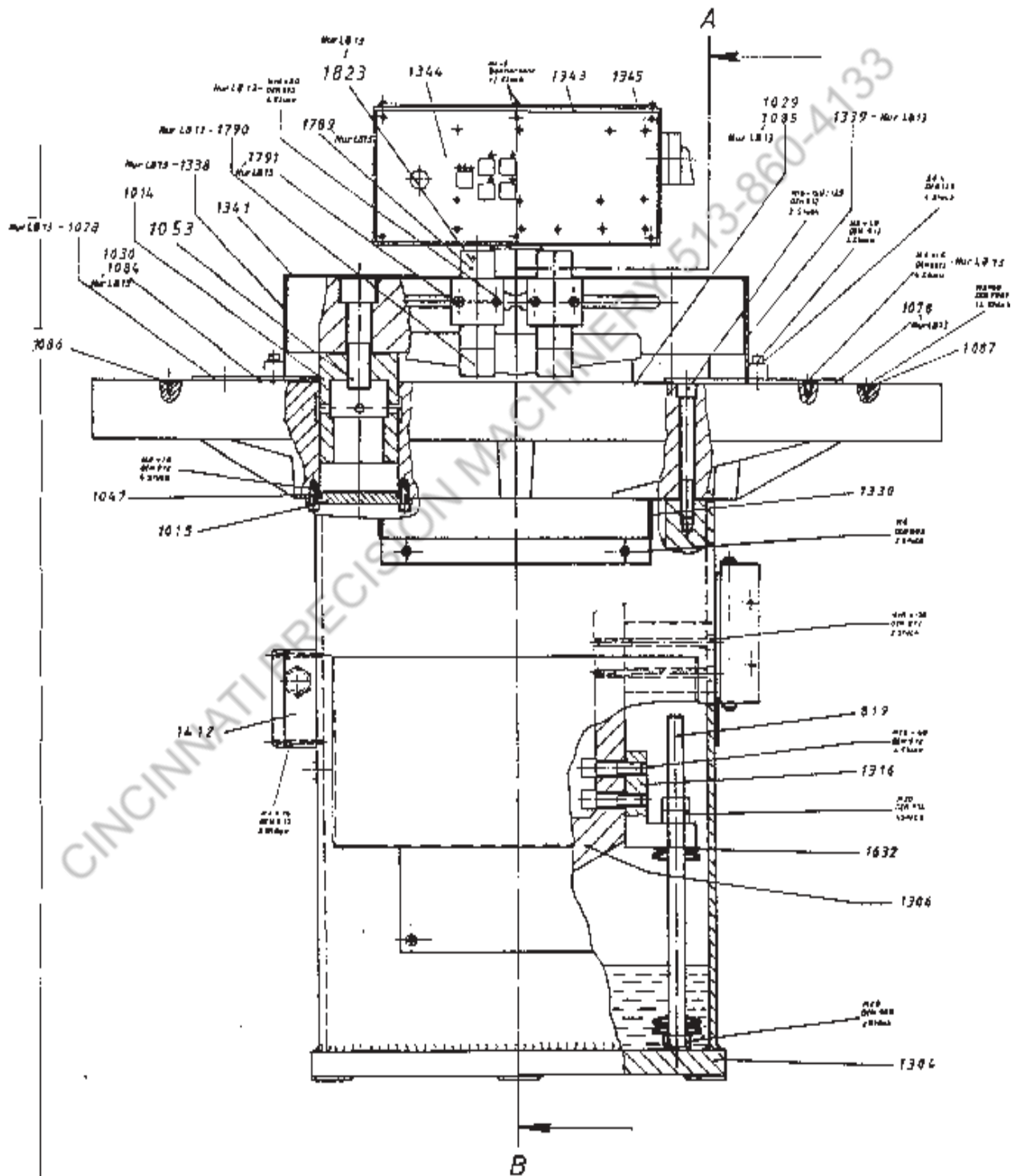

## 9.2 Section A - B

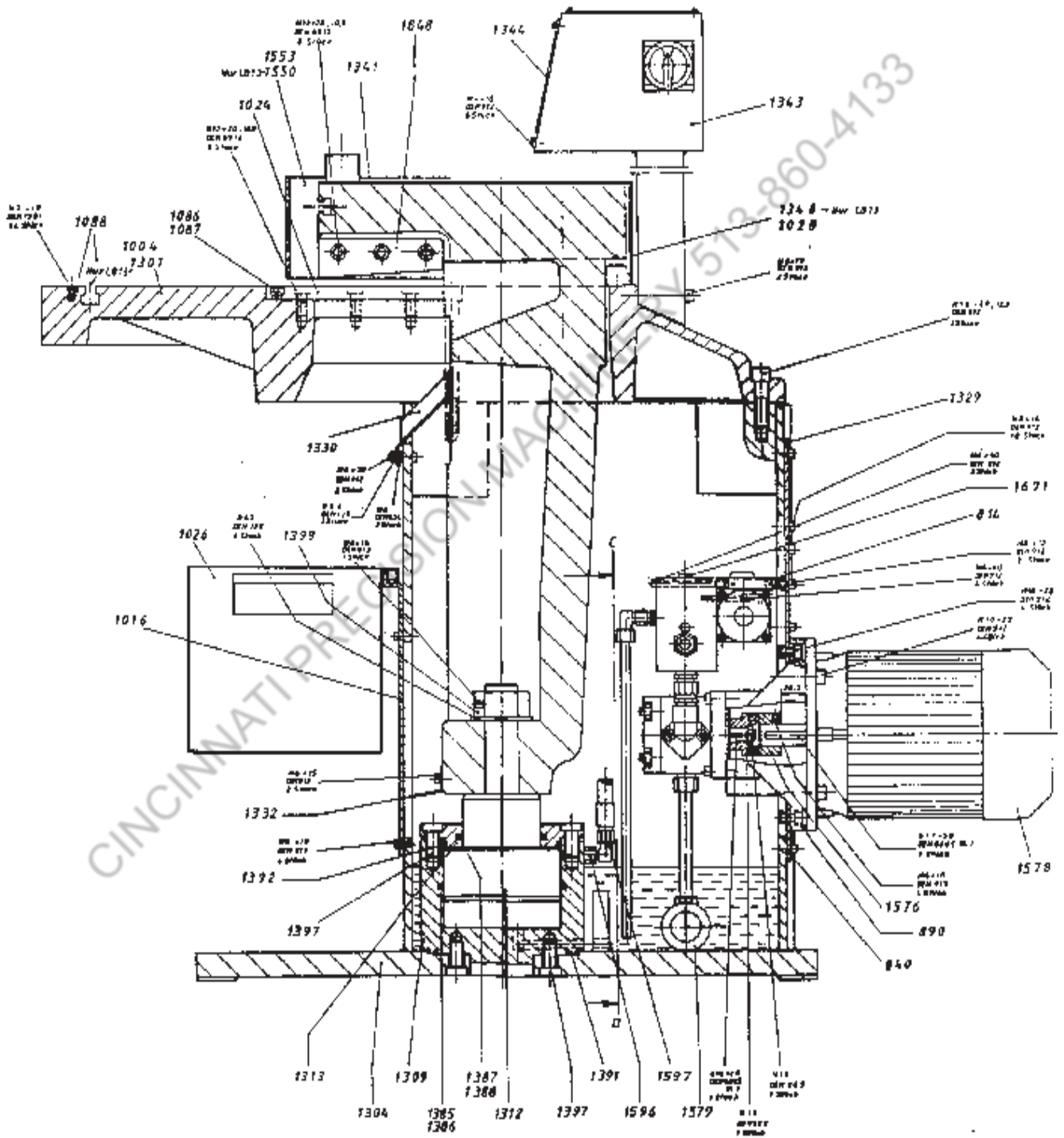

## 9.3 Section C - D

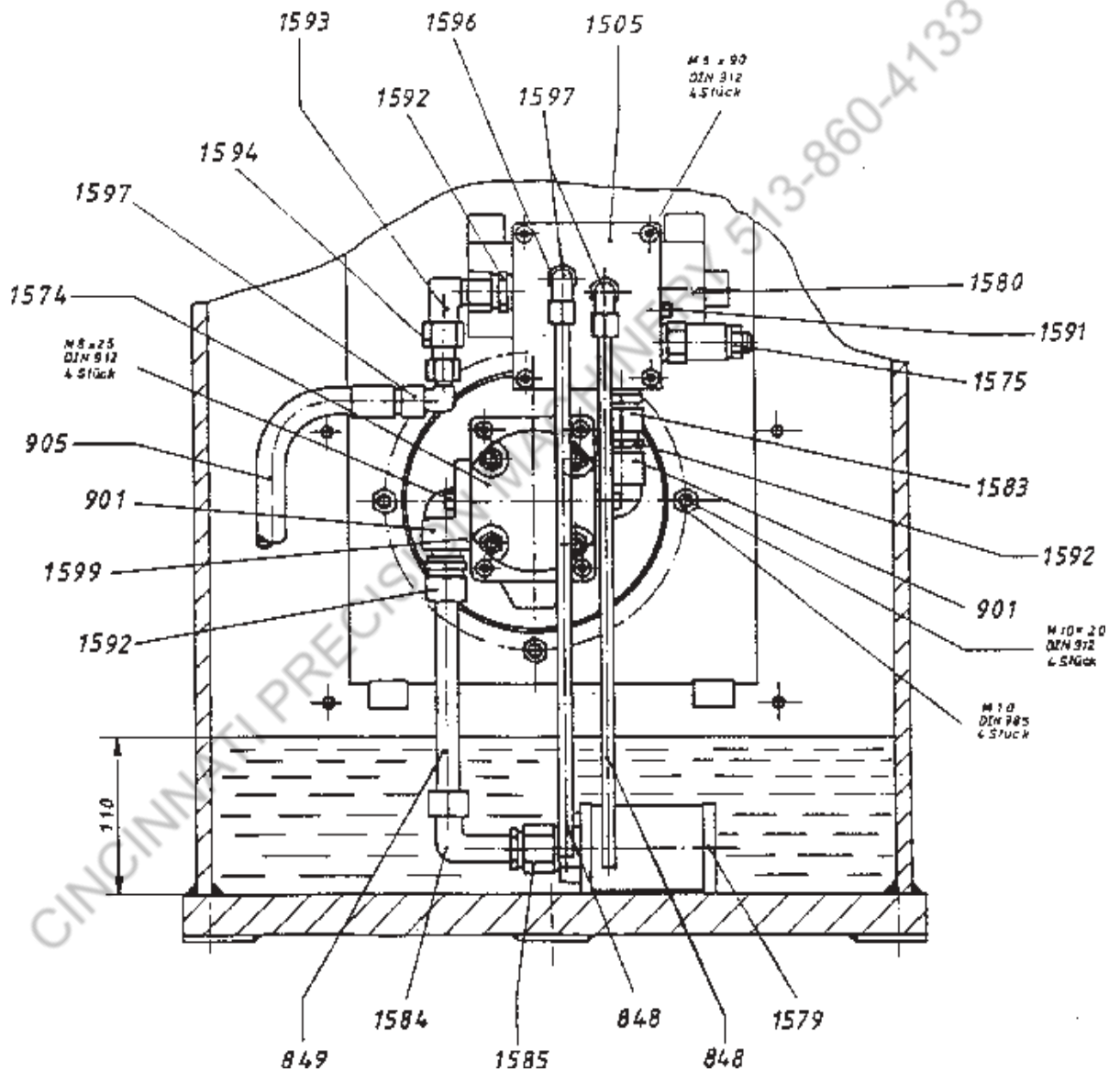

## 9.4 Disk spring column

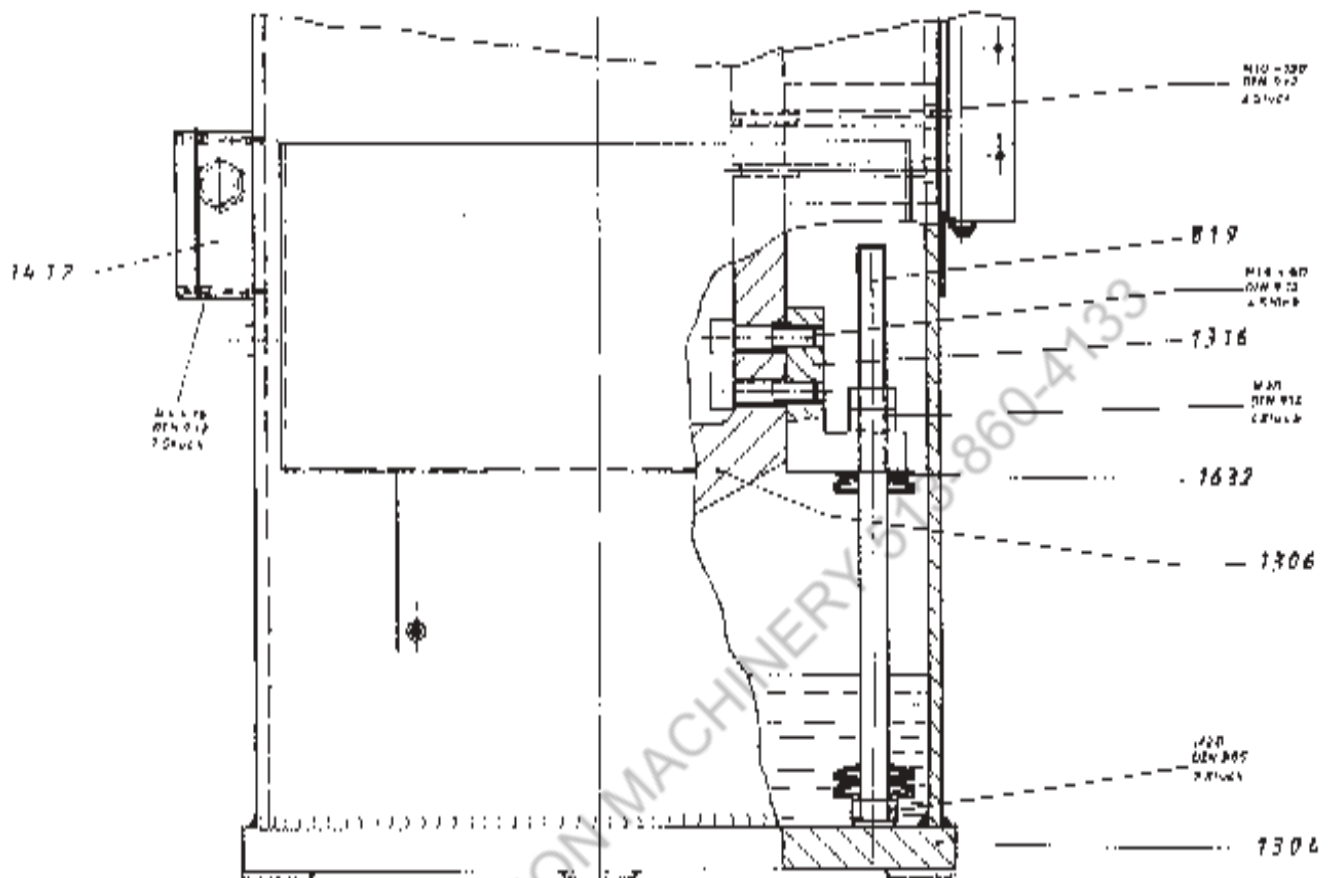

## 9.5 Instructions for changing the ram return springs

1. Remove front cover. (In back of the waste box)
2. Jog the Ram to its lowest position.
3. Tighten the M-20 nut on upper threaded rod until it is against the L-bracket. **NOTE:** *Some machines have two stacks of springs.*
4. Jog the Ram to the upper position.
5. Remove the M-16 screws on the L-bracket and remove complete spring package.
6. Change the springs (making sure to stack them in proper order) and re-assemble in machine.

## 10 Electrical

### 10.1 Changing machine voltage

There are three steps to changing the voltage:

1. Changing jumpers in the terminal box of the motor
2. Changing the control transformer in the control panel box
3. Changing the overload either in the control panel box or at the main disconnect.

1. Most machines have nine poles in the terminal box which should be set as shown below. Some machines may have six poles, in which case three jumpers should run vertically for 220V and the V2, U2 and W2 poles should be connected for 440 V.



220 Volts



440 Volts

2. The control transformer is in the control panel box. Remove the six screws and set the transformer incoming lines and jumper as shown below:



Spanning = Voltage

Anschluss = Incoming Lines

Brücke = Bridge or Jumper

220V: Jump 1 to 37 and 2 to 33

440V: Jump only 32 to 37

460V: Jump only 33 to 37

480V: Jump only 34 to 37

3. The overload in the control panel box needs to be changed so it has the proper amperage. For 200 - 240 Volts, the range of amps is 16 - 20 (set at 17). For 400 to 490 Volts, the range of amps is 6 - 10 (set at 10). If the amperage cannot be adjusted to the safe setting, the overload protection must be changed. Contact Boschert for the correct parts.

### 10.2 Electrical plan USA

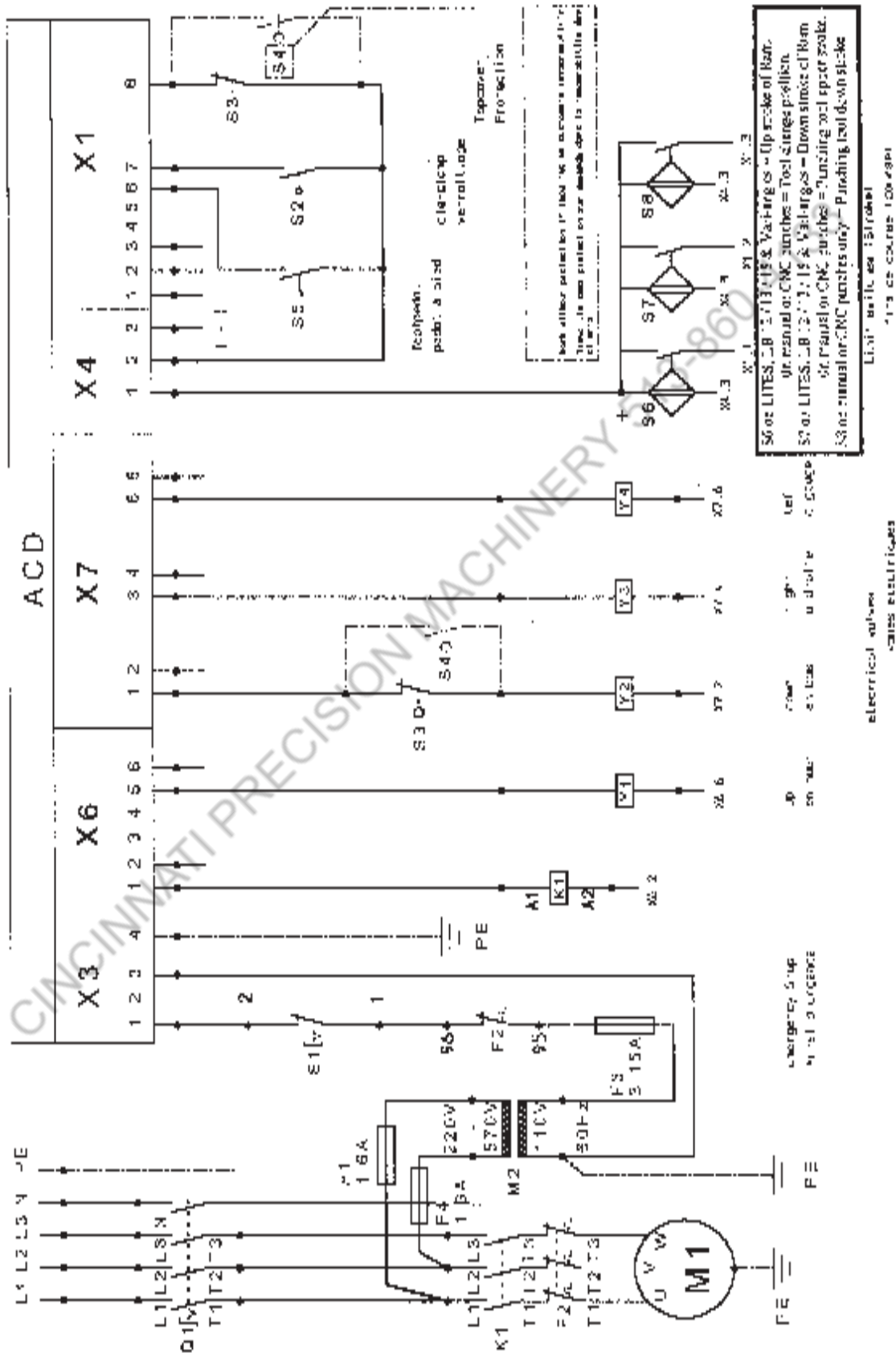

### 10.3 Electrical parts list USA

Nr.	Typ	Function	Pns	Ih12	h17	h15	X30	X20	Vol	U131	U30n	U1	U2	U3	U4	U5	U6	U7	U8	U9	U10	U11	U12	U13	U14	U15	U16	U17	U18	U19	U20	U21	U22	U23	U24	U25				
1	112 B3/55	Motor	X	X	X	X	X	X	X	X	X	X	X	X	X	X	X	X	X	X	X	X	X	X	X	X	X	X	X	X	X	X	X	X	X	X	X	X		
2	Kalifa 104	Mo nswitch	X	X	X	X	X	X	X	X	X	X	X	X	X	X	X	X	X	X	X	X	X	X	X	X	X	X	X	X	X	X	X	X	X	X	X	X	X	
3	SK 20x7 1.6A	Fuse 1.6A	X	X	X	X	X	X	X	X	X	X	X	X	X	X	X	X	X	X	X	X	X	X	X	X	X	X	X	X	X	X	X	X	X	X	X	X	X	
4	M23K 15-23A	Overload relay	X	X	X	X	X	X	X	X	X	X	X	X	X	X	X	X	X	X	X	X	X	X	X	X	X	X	X	X	X	X	X	X	X	X	X	X	X	X
5	SK 20x5 3 15A	Fuse 3 sec	X	X	X	X	X	X	X	X	X	X	X	X	X	X	X	X	X	X	X	X	X	X	X	X	X	X	X	X	X	X	X	X	X	X	X	X	X	X
6	SK 20x7 1.6A	Fuse 1.6A	X	X	X	X	X	X	X	X	X	X	X	X	X	X	X	X	X	X	X	X	X	X	X	X	X	X	X	X	X	X	X	X	X	X	X	X	X	X
7	RLSK LC	Relays	X	X	X	X	X	X	X	X	X	X	X	X	X	X	X	X	X	X	X	X	X	X	X	X	X	X	X	X	X	X	X	X	X	X	X	X	X	X
8	32450C300	Emergency switch	X	X	X	X	X	X	X	X	X	X	X	X	X	X	X	X	X	X	X	X	X	X	X	X	X	X	X	X	X	X	X	X	X	X	X	X	X	X
9	63 15L:K34	Disconnecting	-	-	-	-	-	-	-	-	-	-	-	-	-	-	-	-	-	-	-	-	-	-	-	-	-	-	-	-	-	-	-	-	-	-	-	-	-	
10	6188A172:4	Limit switch	-	-	-	-	-	-	-	-	-	-	-	-	-	-	-	-	-	-	-	-	-	-	-	-	-	-	-	-	-	-	-	-	-	-	-	-	-	
11	3733521E0	keyswitch	-	-	-	-	-	-	-	-	-	-	-	-	-	-	-	-	-	-	-	-	-	-	-	-	-	-	-	-	-	-	-	-	-	-	-	-	-	
12	F1-L1-UV	front panel	X	X	X	X	X	X	X	X	X	X	X	X	X	X	X	X	X	X	X	X	X	X	X	X	X	X	X	X	X	X	X	X	X	X	X	X	X	X
13	65229C300	Limit switch	X	X	X	X	X	X	X	X	X	X	X	X	X	X	X	X	X	X	X	X	X	X	X	X	X	X	X	X	X	X	X	X	X	X	X	X	X	X
14	65229C300	Limit switch	X	X	X	X	X	X	X	X	X	X	X	X	X	X	X	X	X	X	X	X	X	X	X	X	X	X	X	X	X	X	X	X	X	X	X	X	X	X
15	65229C300	Limit switch	-	-	-	-	-	-	-	-	-	-	-	-	-	-	-	-	-	-	-	-	-	-	-	-	-	-	-	-	-	-	-	-	-	-	-	-	-	
16	VAC21220	prog vs vp	X	X	X	X	X	X	X	X	X	X	X	X	X	X	X	X	X	X	X	X	X	X	X	X	X	X	X	X	X	X	X	X	X	X	X	X	X	X
17	VAC21220	prog vs vp	X	X	X	X	X	X	X	X	X	X	X	X	X	X	X	X	X	X	X	X	X	X	X	X	X	X	X	X	X	X	X	X	X	X	X	X	X	X
18	VSS21220	prog vs vp	-	-	-	-	-	-	-	-	-	-	-	-	-	-	-	-	-	-	-	-	-	-	-	-	-	-	-	-	-	-	-	-	-	-	-	-	-	
19	VSS21220	prog vs vp	-	-	-	-	-	-	-	-	-	-	-	-	-	-	-	-	-	-	-	-	-	-	-	-	-	-	-	-	-	-	-	-	-	-	-	-	-	
20	connection	X4, 2XK: 7	X	X	X	X	X	X	X	X	X	X	X	X	X	X	X	X	X	X	X	X	X	X	X	X	X	X	X	X	X	X	X	X	X	X	X	X	X	X
21	connection	X4, 2XK: 0	X	X	X	X	X	X	X	X	X	X	X	X	X	X	X	X	X	X	X	X	X	X	X	X	X	X	X	X	X	X	X	X	X	X	X	X	X	X
22	3YP	transformer	X	X	X	X	X	X	X	X	X	X	X	X	X	X	X	X	X	X	X	X	X	X	X	X	X	X	X	X	X	X	X	X	X	X	X	X	X	X
23	-	-	X	X	X	X	X	X	X	X	X	X	X	X	X	X	X	X	X	X	X	X	X	X	X	X	X	X	X	X	X	X	X	X	X	X	X	X	X	X
24	-	-	X	X	X	X	X	X	X	X	X	X	X	X	X	X	X	X	X	X	X	X	X	X	X	X	X	X	X	X	X	X	X	X	X	X	X	X	X	X
25	-	-	X	X	X	X	X	X	X	X	X	X	X	X	X	X	X	X	X	X	X	X	X	X	X	X	X	X	X	X	X	X	X	X	X	X	X	X	X	X



### 10.4 ACD tableau USA

## ACD Tableau

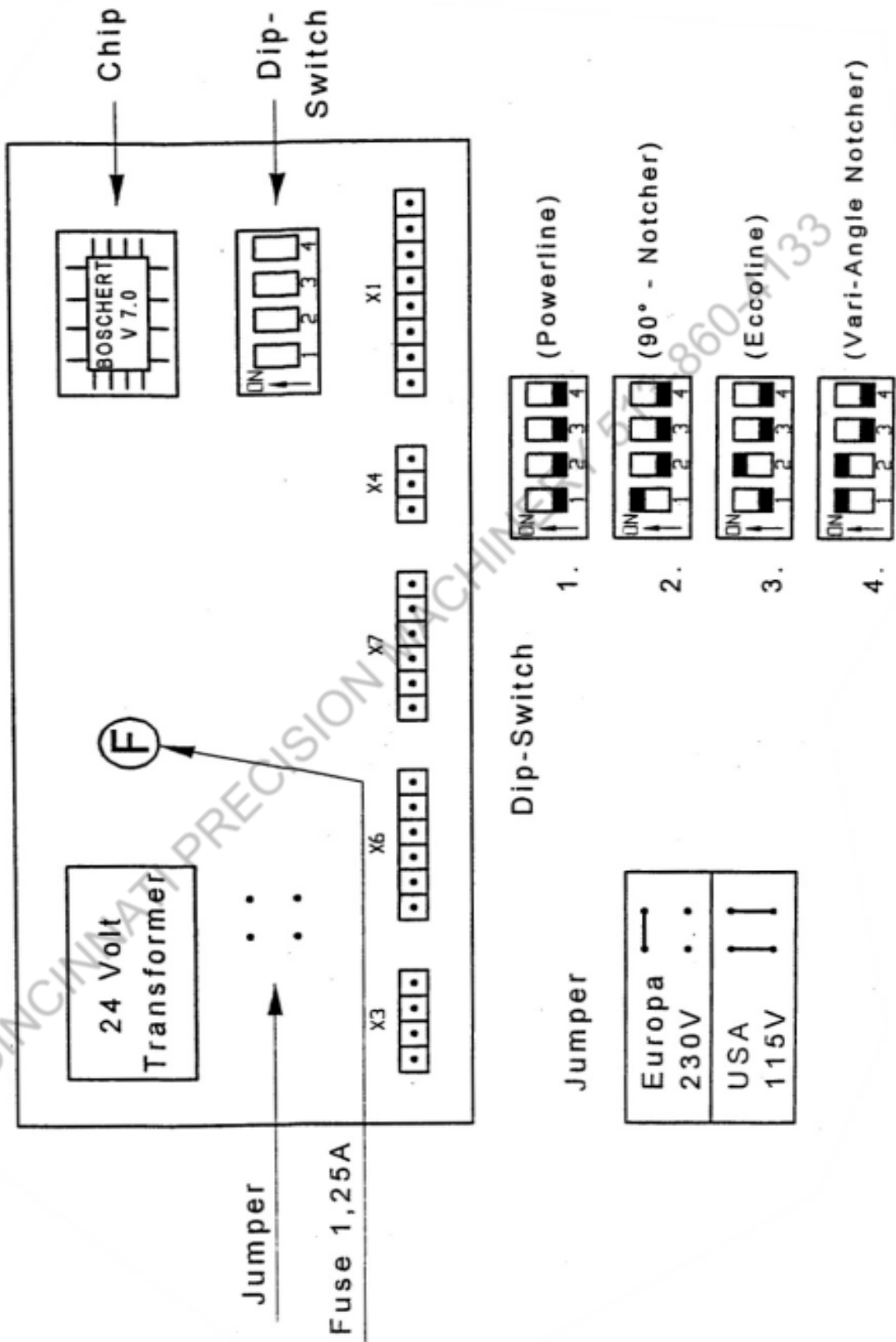

## 12.1 Spare parts

---

- Store spare parts that cannot be delivered in the short run. Loss of production is more expensive than storage.
- In your interest:, use our original spare parts.

### Spare parts delivered by us:

- are checked and released by us
- do not affect functioning and safety of the machine
- are state-of-the-art and comply with legal regulations
- are covered by our liability and guarantee

### When ordering spare parts, please indicate the following data:

- Your ordering no.
- Name of spare part
- Article no. (if available)
- Dimensions
- Number of pieces

## 12.2 Spare parts lists, spare parts graphics

---

Further information is provided by our spare parts lists and spare parts graphics.

## 12.3 Address for spare parts and after-sales service

---

### **Boschert Precision Machinery Inc.**

P.O. Box 409  
Butler, WI 5300-0409

USA

Telephone: 262-783-7816

Telefax: 262-373-1165

[www.boschertusa.com](http://www.boschertusa.com)

[sales@boschertusa.com](mailto:sales@boschertusa.com)

If you require a customer service mechanic please inform us. He will visit you as soon as possible.

## 12.4 Spare parts list

Machine typ	Description	Order no.
Lite	upper blade (set/ 2 pieces)	20312400
Eagle	upper blade (set/ 2 pieces)	20312399
Lite & Eagle	lower blade (set/ 2 pieces)	20312401
Lite & Eagle	plexiguard hight 4,7 inch mm without holddown	20312402
Lite & Eagle	plexiguard hight 7,9 inch with holddown	20312404
Lite & Eagle	plate spring for backstroke (130 pieces)	20312405
Lite & Eagle	fan blades	20312408
Lite & Eagle	brass scale, left, 0-7 inch	20312418
Lite & Eagle	brass scale, right, 0-7 inch	20312419
Lite & Eagle	brass scale, left, 0-9 inch	20312420
Lite & Eagle	brass scale, right, 0-9 inch	20312421
Silver Eagle	upper blade (set/ 2 pieces)	20322400
Silver Eagle	lower blade (set/ 2 pieces)	20322401
Silver Eagle	plate spring for backstroke(130 pieces)	20322402
Silver Eagle	plate spring for holddown (50 pieces)	20322403
Silver Eagle	plexiguard hight 7,9 inch with holddown	20322406

CINCINNATI PRECISION MECHANICAL MACHINERY 513-860-4123

## 12.5 Features of the new patented horizontal hold down stop bar

### Standard Equipment on the Eagle and Eagle 250

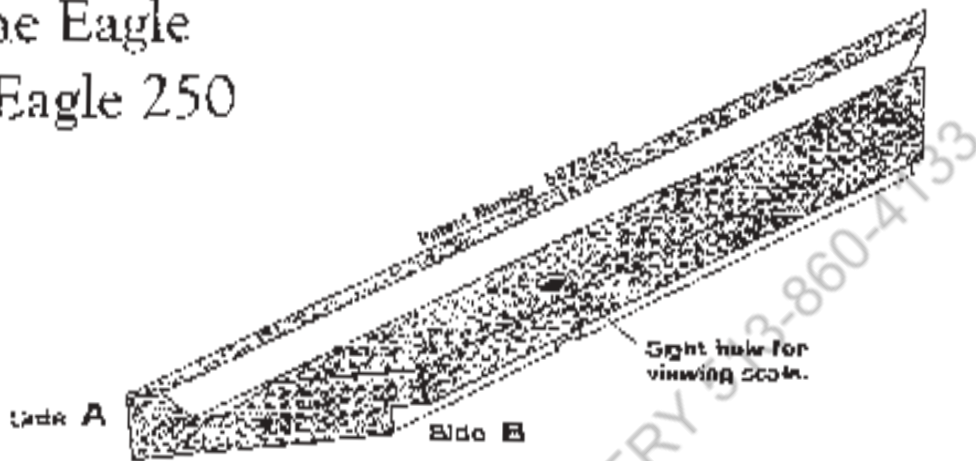

SIDE A

SIDE B

For normal notching of larger sheets. To accurately adjust the bar the operator reads the scale directly from the bottom edge of the bar.

The patented milled relief is oversized so the operator can push the material under the lip to eliminate the material from jumping. Especially useful for notching smaller pieces. The operator aligns the bar by sighting through the hole in the top of the bar.

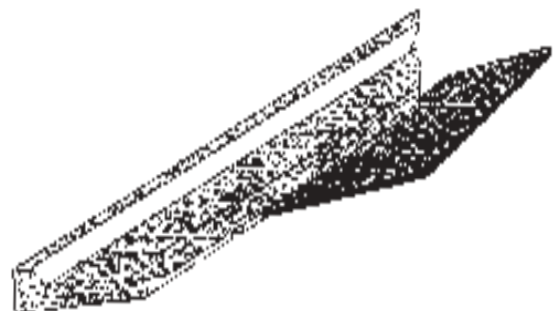
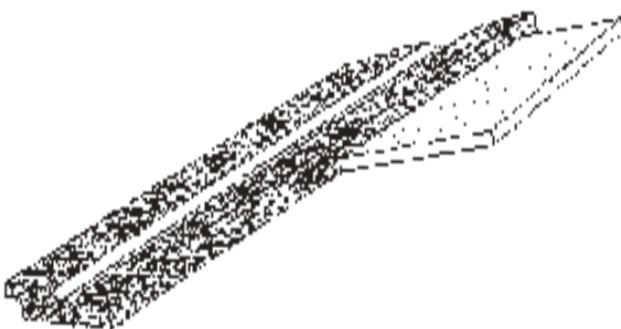

## 12.6 Locking bolt Boschert **LITE**

21205021

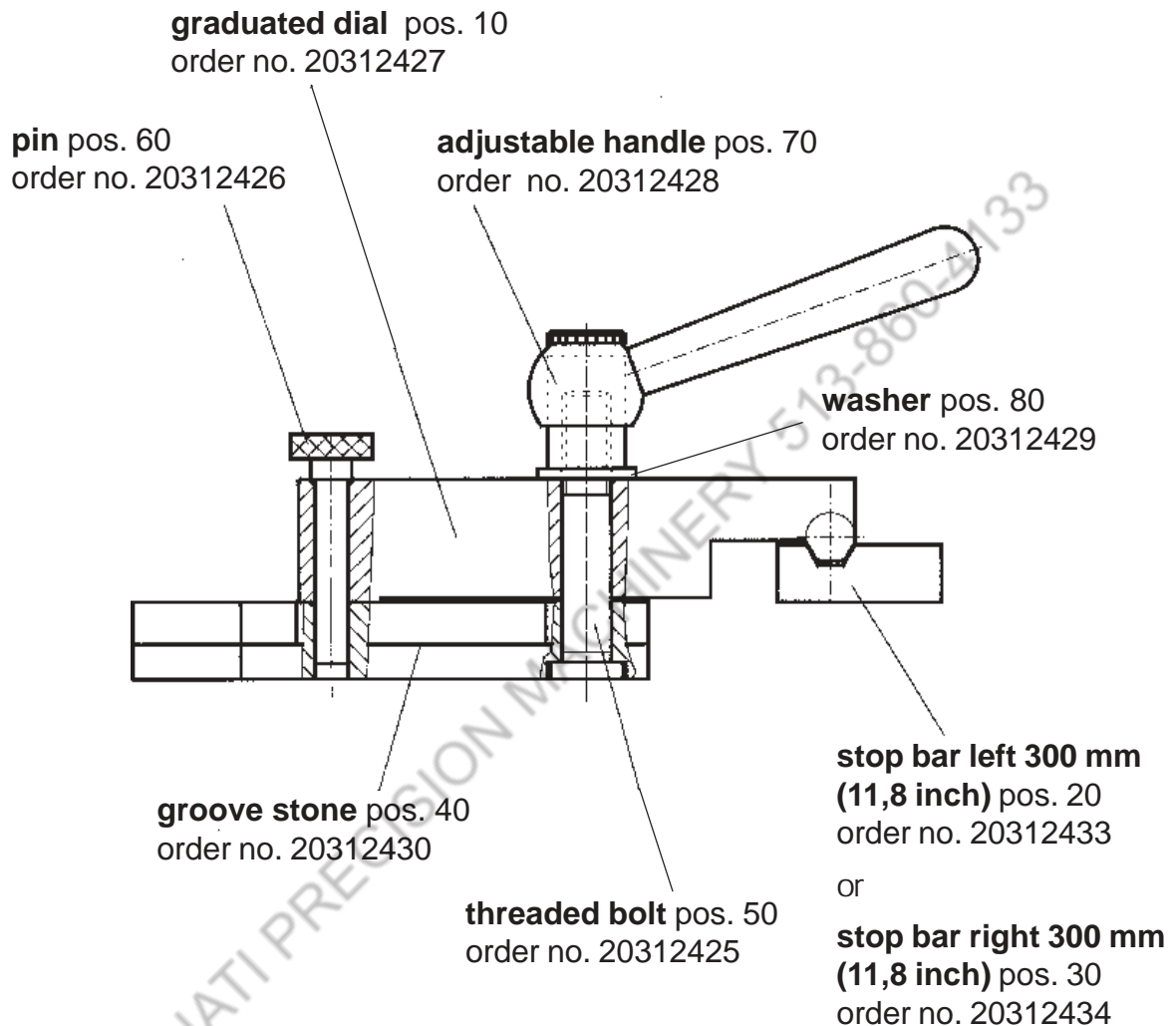

**locking bolt complete mounted  
without stop bar**  
order no. 20312435

**locking bolt complete mounted  
with stop bar 300 mm  
(11,8 inch)** order no. 20312437

## 12.7 Locking bolt Boschert **EAGLE** 21205021

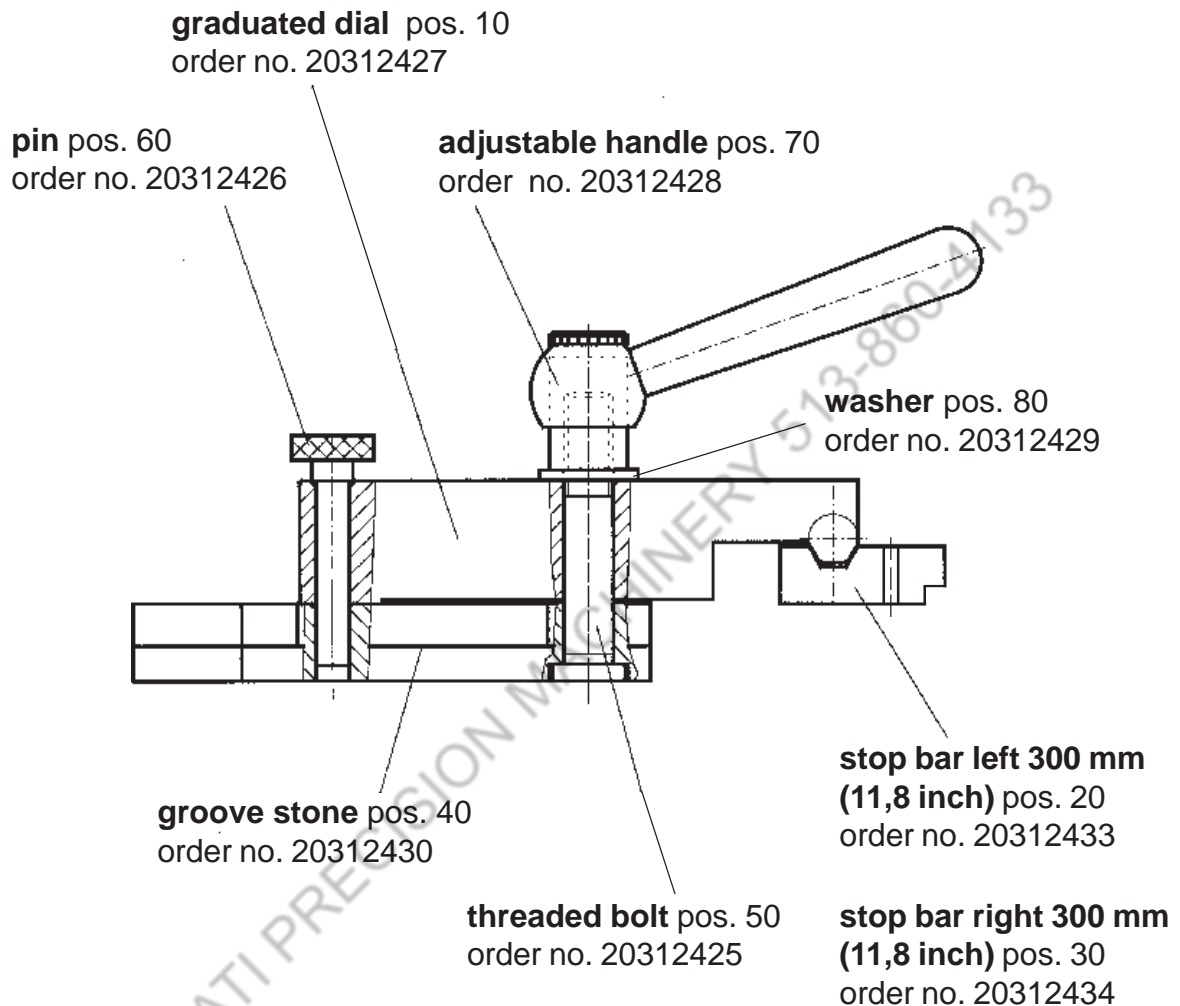

**locking bolt complete mounted  
without stop bar**  
order no. 20312435

**locking bolt complete mounted  
with stop bar 300 mm  
(11,8 inch)** order no. 20312437

## 12.8 Locking bolt Boschert **SILVER EAGLE** 21205021

**graduated dial** pos. 10  
order no. 20322410

**pin** pos. 60  
order no. 20322408

**adjustable handle** pos. 70  
order no. 20322409

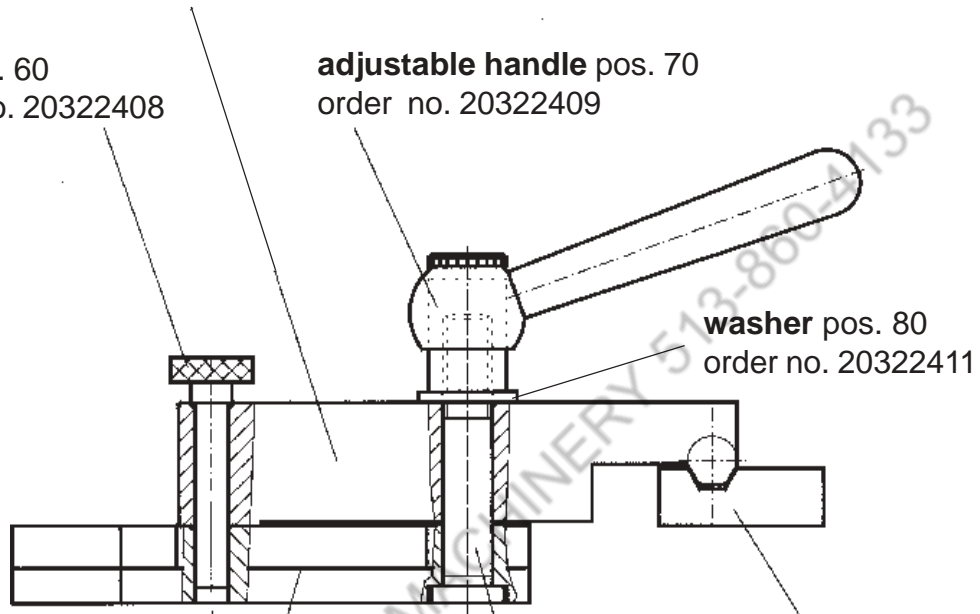

**washer** pos. 80  
order no. 20322411

**groove stone** pos. 40  
order no. 20322412

**stop bar left 500 mm  
(19,7 inch)** pos. 20  
order no. 20322414

**threaded bolt** pos. 50  
order no. 20322413

**stop bar right 500 mm  
(19,7 inch)** pos. 30  
order no. 20322415

**locking bolt complete mounted  
without stop bar**  
order no. 20322416

**locking bolt complete mounted  
with stop bar 500 mm (19,7 inch)**  
order no. 20322417

## 12.9 Locking bolt parts list 21205021

Pos.	Artikelnr.	Artikelname	Abmaße	Einzelpreis	Stück	TIN	Werkstoff
10	22520059 0	Graduated disc	Rd140x30		2		C45
20	22515172 0	Stop bar left	40x14x500		1		C45
30	22515173 0	Stop bar right	40x14x500		1		C45
40	22520060 0	Sliding block	24x49,5x125		2		C45
50	22515231 0	Threaded bolt	Rd17,5x70		2		C45
60	23515300 0	Socket pin	rd20x55		2		C45 br0
70	98015205 0	Adjustable ball lever	M12		2		St
80	79110512 0	Plain washer	M12		2	125	St

CINCINNATI PRECISION MACHINERY 513-860-4133



## 12.10 Inside stop Boschert Lite, Eagle and Silver Eagle

21205017 / 21205001



Not available on Boschert Lite

## 12.11 Mini stop (optional) 21205007

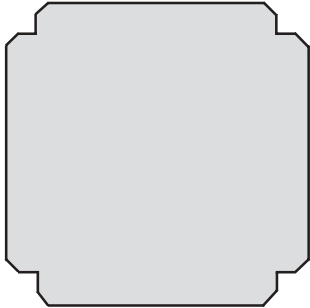

**Mini stop**  
order no. 20310001



Sample for mini stops to avoid additional setting of the standard stops.

## 12.12 Stroke adjustment Boschert Lite, Eagle and Silver Eagle

---

**Limit switch**  
order no. 20310000

CINCINNATI PRECISION MACHINERY 513-800-1133

### 12.12 Stroke adjustment Boschert Lite, Eagle and Silver Eagle

---

**To lengthen or shorten the downward stroke of the cutting blades below the table surface:**

1. Loosen set screw on lower locking nut.
2. To lengthen stroke, move knurled nut and locking nut upwards; to shorten stroke, move knurled nut and locking nut downwards.
3. Tighten set screw at desired position.

**To raise or lower the upper limit of the cutting blades:**

1. Loosen set screw on upper locking nut.
2. To raise the upper stroke limit, move knurled nut and locking nut downwards; to lower the limit, move knurled nut and locking nut upwards.
3. Tighten set screw at desired position.

CINCINNATI PRECISION MACHINERY 513-860-4133

## 12.13 Hold down Boschert **SILVER EAGLE, EAGLE 250** 21203014

---

**Hold down complete**  
order no. 20322430

**Hold down t-bar** pos. 1791  
order no. 20322433

**Hold down sleeve**  
pos. 1789  
order no. 20322431

**Disk spring for hold down**  
pos. 1823  
order no. 20322434  
(34x14x1.5mm)

**Hold down piston**  
pos. 1790  
order no. 20322432

**Problem:** Fuse blows on circuit board

**Process:** Check to see if circuit board is bad or if there is another problem

Check the 3.5 amp fuse on the circuit board (located in the small black cylinder on the circuit board). If the fuse blows again, the cause could be a bad circuit board or a bad proximity switch.

To check the circuit board, remove the screws holding the board to the control box and disconnect all the plugs except the „power in“ plug on the extreme left side as you face the machine. Put a new fuse in the circuit board and turn the machine on again. If the fuse blows, the board has been damaged and needs to be replaced. Contact Boschert for part # 1344.

If the fuse does not blow, the problem is most likely in one of the proximity switches. Check the switches by exchanging them and isolate the failing switch.

CINCINNATI PRECISION MACHINERY 513-807-4133