

VD CAP WASHERS / GREASE BOLTS

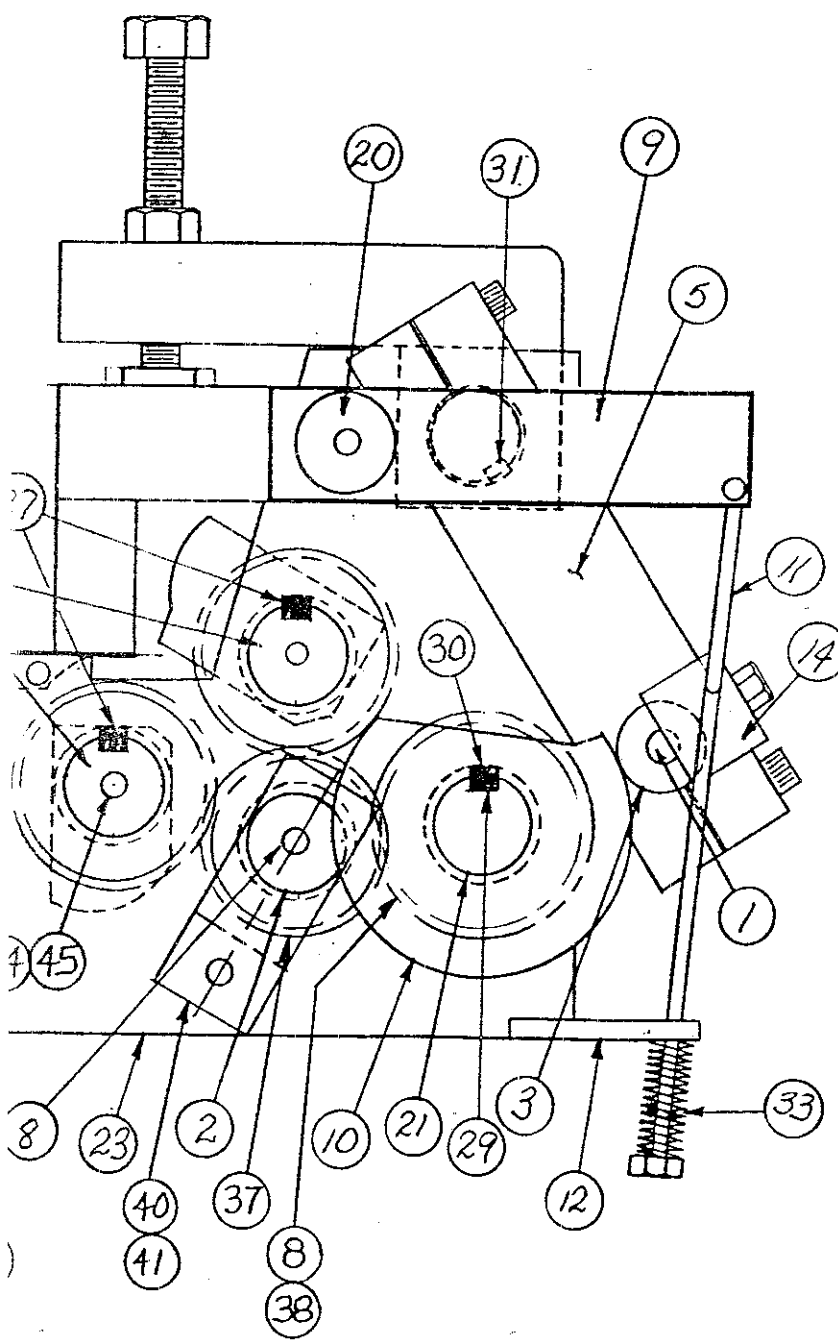

48	1	4165-7	X	GREASE
47	2	4165-1	X	GREASE
46	2	EP511178	X	4219-4 E
45	2	EP511193	X	4219-9 E
44	2	EP531239	X	5212-45°
43	1	EP573003	X	5100-125 1
42	1	A-1069194	X	SPACER
41	1	A-1073153	X	IDLER SH
40	1	A-1073152	X	IDLER SH
39	5	EP513035	X	1/4" SET C.
38	9	EP511108	X	TRB-2031
37	1	A-2773	X	IDLER GEA
36	10		X	5/16-17x1 5
35	6		X	5/16-17x3/4 HL
34	3		X	1/2-13x3 10ms
33	1	EP571038	X	COMPRESSI
32	3	B-1068037-2	X	CLAMPING
31	2	A-1068632-5	X	CLAMPING A
30	1	A-1068632-4	X	SPUR GE
29	2	A-1068632-3	X	ECCENTRIK
28	3	A-1068632-2	X	CLAMPING
27	2	A-1068632-1	X	SPUR GEAR
26	1	D-1066864	X	LOWER U
25	1	D-1066865	X	UPPER U
24	1	D-1066869	X	CLAMPING
23	2	C-1068036	X	RIGHT SH
22				
21	1	B-1068039	X	TIMING S
20	1	B-1068038	X	CLAMPING
19	3	B-1068041	X	1" CLAMP
18				
17	1	B-348	X	BENDING
16	1	B-347	X	SPRING STEE
15	1	A-1068221	X	CAM TIM
14	2	A-1068220	X	CAM BEAR
13	1	H-1068611	X	CAM SHAFT
12	1	A-1068093	X	TENSION S
11	1	A-1068042	X	TENSION S
10	2	A-1068039	X	ECCENTRIK
9	1	A-1068033	X	SPRING LIF
8	1	A-2772-1	X	SPUR GE
7	2	A-2772	X	SPUR GE
6	1	A-57	X	REAR ANGL
5	2	A-460	X	HOLD DOWN
4	1	A-339	X	FRONT AN
3	2	A-8034	X	CLAMPING
2	1	A-325	X	IDLER SHAFT
1	2	A-324	X	ECCENTRIC

ITEM	REQ'D.	SYMBOL	PURCHASE
ENGEL INDUSTRIES, INC.			
DATE 5-24-77			O.T./C.E.
SCALE NONE			
DRAWN R.J.			

MACHINERY 513-860-4133

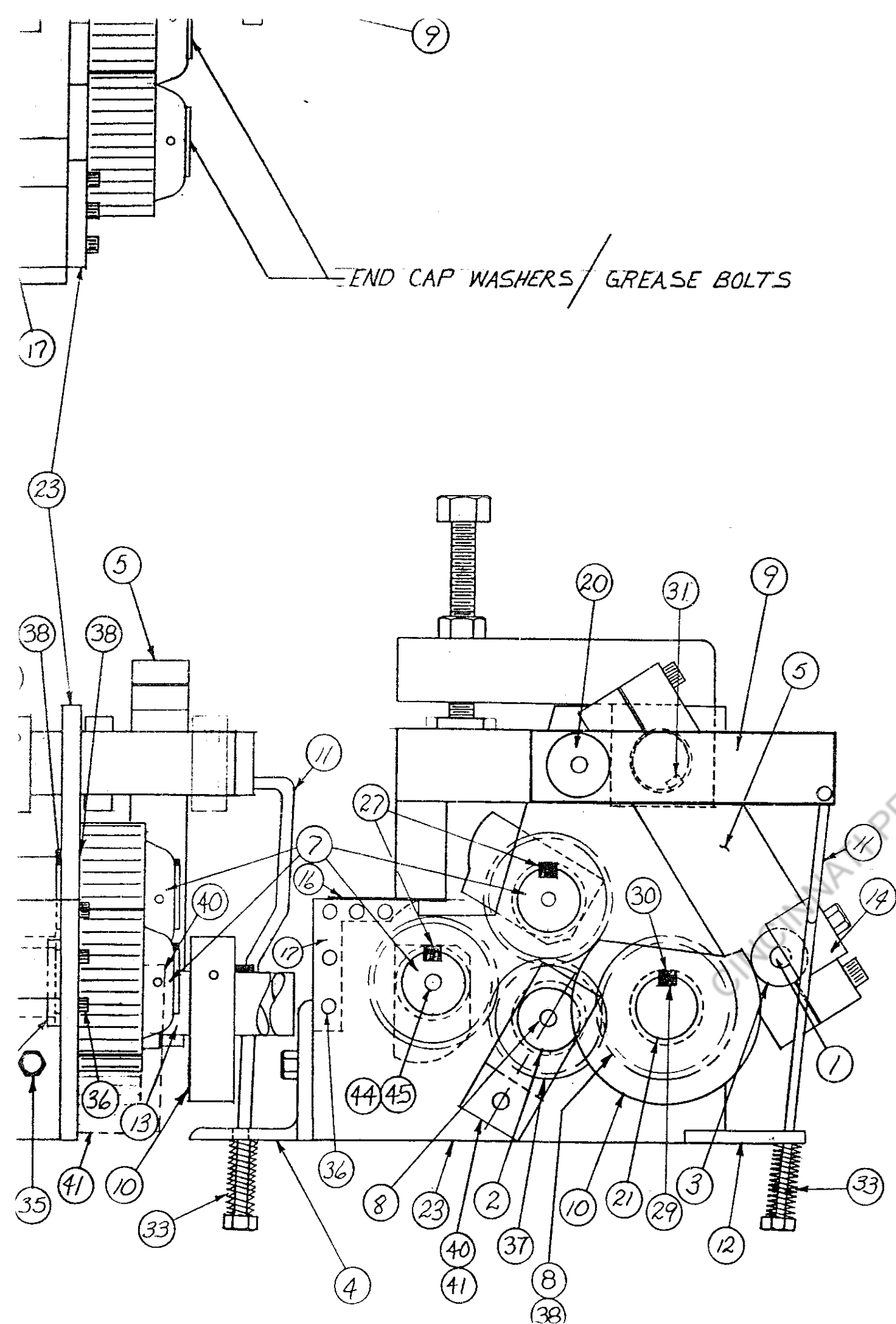

48	1
47	2
46	2
45	2
44	2
43	1
42	1
41	1
40	1
39	5
38	9
37	1
36	10
35	6
34	3
33	1
32	3
31	2
30	1
29	2
28	3
27	2
26	1
25	1
24	1
23	2
22	
21	1
20	1
19	3
18	
17	1
16	1
15	1
14	2
13	1
12	1
11	1
10	2
9	1
8	1
7	2
6	1
5	2
4	1
3	2
2	1

MACHINERY 513-860-4133

