

Engel Shopmaster

M-519

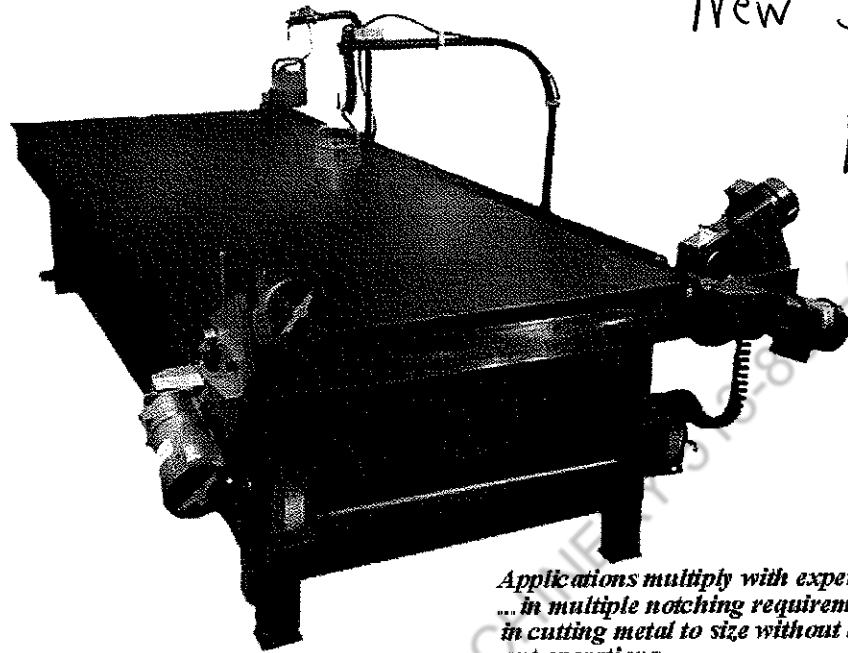

New Style

↓ (2) motors per cutter

Applications multiply with experience of user ... in multiple notching requirements and in cutting metal to size without laying out operations.

Features

Model	Sheet Size	Required Floor space Length	Width	Approx. Shipping WT.-LBS.
818-4	96in. x 48 in.	152 in.	59 in.	1600
1018-4	120 in. x 48 in.	176 in.	59 in.	2000
1018-52 in.	120 in. x 52 in.	176 in.	63 in.	2100
1018-5	120 in. x 60 in.	176 in.	71 in.	2400

Specifications

Maximum Capacity: 18 gauge mild steel or equivalent. (16 gauge optional)

Working Height: 31 in.

End Motorized Cutter: Dual 1/6 HP Gear Motor 110V 60Hz, single phase Rate of Travel 60 FPM

Length Motorized Cutter: Dual 1/6 HP Gear Motors 110 V, 60 Hz, single phase Rate of Travel 85 FPM

Magno Pak Units: 110 V, 60 Hz, Single Phase

Low profile cutters for minimum lift and burr. Twin oil bath gear box drive.

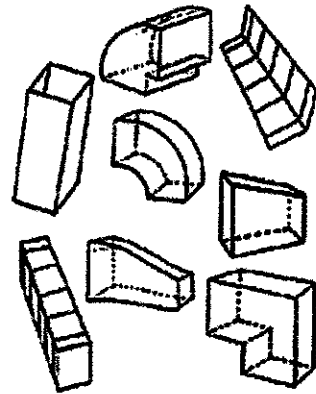
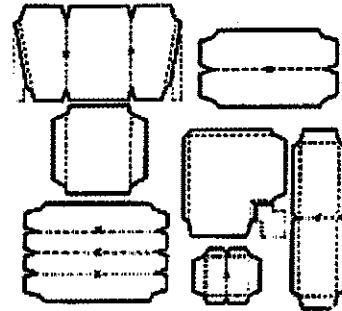

ENGEL 
INDUSTRIES

8122 Reilly Ave. St. Louis, MO 63111 Phone (314) 638-0100 Fax (314) 638-4048 www.engelind.com

Cutter Cords:

ECC: New style cutter cord (2 motors) - *short*

ECC-O/S: Old style--1 motor

LCC: Length cutter cord-New style (2 motors)

LCC-O/S: old style (1 motor)

PART NUMBER

DESCRIPTION

PRICE

PART NUMBER	DESCRIPTION	PRICE
400-4 708	Back Chain Guard Assy.	
400-5 709	Front Chain Guard Assy.	
400-6		
400-7 710	Belt Guard Assy.	
B-1 511171	Track Bearing	
B-2 511055	Nice Bearing	
B-3 511056	Drive Shaft End Bearing	
B-4 "		
B-5 511201	Bronze Bushing	
B-6 511054	Cutter Wheel Bearing	
G-1 2761	Cluster Gear & Sprocket	
G-2 2762	Spur Gear	
G-3 514002	Worm Gear Bronze	
G-4 2764	Chain Sprocket	
G-5 2765	Chain Sprocket	
G-6 514001	Worm Gear Cutter	
S-2 571017	Spring	
P-1 512059	Sheave	
P-2 512036	Pulley	
V-1 562002	4L190	
V-2 562003	V-Belt (18 ga. cutter)	
W-1	1/4" Flat Washer	
W-2 8207-13	5/16" ID x 3/4" OD Plain washer	
W-3 512084	Shim 5/8 x 1 x .020	
W-6	1/4" Lock Washer	
W-7 511257	Aircraft washer 3/8 x 5/8 x .064	

MICROSWITCH
 OLD 551080 1-motor
 NEW 551058 2-motor

CINCINNATI PRECISION MACHINERY 513-860-4133

6657/0012-1 Humphrey Valve Repair Kit
 Completed Cutter Foot Petal

M-400-18

PART NUMBER		DESCRIPTION	PRICE
40-1	542014	Cutter Wheel	
40-2	712	Eccentric Bushing	
40-3-1	713	Sprocket gear key cutter	
40-3-2	714	Spur gear key cutter	
40-4-1	724	Cutter Bolt	
40-4-2	842-1	Cutter Bolt use 842-1	
40-5-1	725	Eccentric Bolt Cutter	
40-5-2	726	Eccentric Bolt Cutter	
40-6	515002	Gits Oiler	
40-7	8192	Cutter Casting	
40-8	572034	Expansion Plug	
40-9	563050	#54 Link Chain (Must specify # of links)	
40-10	563050	#62 Link Chain (must specify # of links)	
40-11	563039	#35 Chain--Connecting Link	
40-12	563038	#35 Chain Offset Link	
40-13	1635	Spacer	
40-14	1636	Handle	
40-15	1637	Drive Shaft	
40-16-1	1638	Lower Shaft'	
40-16-2	1639	Upper Shaft	
40-17			
40-18	1641	Belt Guard Plate	
40-19	513032	5/8" Set Collar	
400-1		Cutter Casting---OBSOLETE	
400-2			

CINCINNATI PRECISION MACHINERY 513-260-1133

ENGEL

INDUSTRIES
ST. LOUIS, MISSOURI

MAGNO-PAK PARTS LIST

(Prices valid as of 12-22-93)

MAGNO-PAK ASSY - M-MPC-1

~~2000~~
\$586.⁵⁰

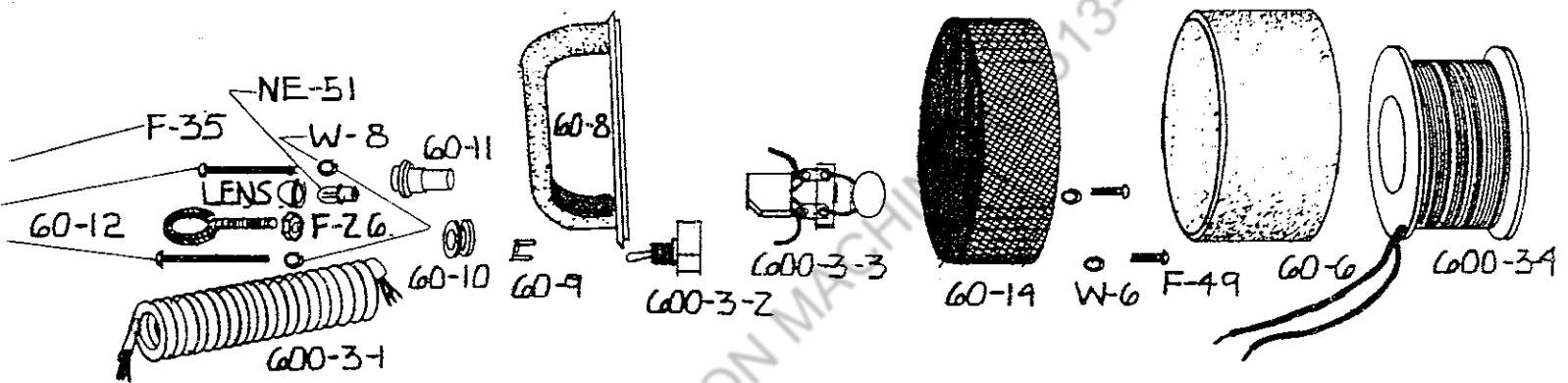

PART NO	QTY. PER UNIT	EP NO.	DESCRIPTION
60-6	1	#1594	BOBBIN HOUSING \$.123 54
60-8	1	#1596	HANDLE 79.48
60-9	1		CORD RETAINING CLAMP
60-10	1	#572123	RUBBER GROMMET INSULATOR 59c
60-11	1	#520001	PILOT LIGHT HOUSING W/LENS \$11.88
60-12	1		HOOK
60-14	1	#1602	PERFORATED METAL SHIELD \$19.49
600-3-1	1	M-RC	RETRACTABLE POWER CORD \$30.55
600-3-2	1	#551024	SWITCH(D.P.S.T.) \$9.52
*600-3-3	1	#553004	SELENIUM RECTIFIER \$31.05
600-3-4	1	#553040	VARISSISTOR \$17.46
NE-51	1	#1068846 (opt.)	BOBBIN W/MAGNET CORD \$181.45
F-26	1	#520032	NEON LAMP \$4.75
F-35	2		NUT 1/4-20
F-49	2		1/4-20 RD HD SCREW X 2-1/2' LG
W-8	2		1/4-20 RD. HD. SCREW X 3/4' LG
W-6	2		1/4" LOCK WASHER
			1/4" SPRING LOCK WASHER
			TOTAL

#531235 *
CINCH CONNECTOR
\$1.13

* Replaced by # 553004 - 553040

* REPLACED BY #553004 + 553040 + 521025

INSTRUCTIONS

ADJUSTMENT OF CUTTER WHEELS:

THE OVERLAP OF $23/64$ " OF THE TWO CUTTING WHEELS WOULD NOT BE CHANGED IN FOLLOWING THE INSTRUCTIONS ABOVE SET OUT SINCE NO CHANGE WAS NECESSARY IN ROTATING THE ADJUSTER BUSHING, 40-2.

THE CLEARANCE BETWEEN THE UPPER CUTTER WHEEL AND THE LOWER CUTTER WHEEL, HOWEVER, MUST BE ADJUSTED TO .002 WHERE THESE CUTTER WHEELS OVERLAP. THIS IS ACCOMPLISHED WHEN THE ALLEN SOCKET HEAD CAP SCREW, F-9, IS LOOSE TO RELEASE THE ADJUSTER BUSHING, 40-2, BY TAPPING EITHER THE $1/2$ " HEX NUT, F-2, OR THE CUTTER BOLT, 40-4-1. USE FEELER GAUGE TO CHECK CLEARANCE. (CAUTION: TO AVOID DAMAGING THE CUTTING EDGES OF THE CUTTER WHEELS, REMOVE "V" BELT FROM PULLEY, P-2, AND PROPEL CUTTERS BY HAND TO MAKE SURE THAT CUTTING EDGES OF CUTTER WHEELS DO NOT BIND OR COME IN CONTACT WITH EACH OTHER AT ANY POINT DURING A COMPLETE ROTATION OF THE CUTTER WHEELS).

AFTER CLEARANCE IS ESTABLISHED, LOCK ADJUSTER BUSHING, 40-2, BY TURNING ALLEN SOCKET HEAD CAP SCREW, F-9, CLOCKWISE.

LUBRICATE SPROCKETS AND CHAINS AND RE-INSTALL THE BACK CHAIN GUARD, 400-4, AND THE FRONT CHAIN GUARD, 400-5.

ADJUSTMENT OF MOTORIZED CUTTERS ON CUTTER TRACKS:

OUR MOTORIZED CUTTERS ARE DESIGNED TO TRAVEL ALONG THE STRAIGHT CUTTER TRACKS IN A SELF-ALIGNING MANNER AND TO EFFECT STRAIGHT CUTTING OF METAL. TO ASSURE THIS TRAVEL FOR STRAIGHT CUTTING, THE $1/4 \times 1\ 1/2$ " ROUND HEAD STOVE BOLT, F-36, IS SET AT THE FACTORY SO THAT THE CUTTER WILL TRAVEL IN A STRAIGHT LINE WITHOUT PULLING OR PUSHING METAL ON OR OFF OF THE TABLE, AND NO FURTHER ADJUSTMENT OF THIS BOLT SHOULD BE REQUIRED IN THE FIELD. IF, HOWEVER, THIS BOLT DOES DRIFT OUT OF ADJUSTMENT, TURN THIS STOVE BOLT, F-36, GRADUALLY CLOCKWISE TO THE POINT WHERE THE CUTTER SLIGHTLY PULLS THE METAL AWAY FROM THE TABLE WHEN CUTTING, AND THEN, GRADUALLY TURN THE SAME BOLT COUNTER CLOCKWISE TO THE POINT WHERE ANY PULLING OF THE METAL IS ELIMINATED IN A CUTTING OPERATION. FINALLY, TURN THE SPRING LOADED $1/4 \times 3$ STOVE BOLT, F-6, CLOCKWISE ONLY TO THE POINT WHERE THERE IS A SLIGHT TENSION ON THE SPRING, S-2, NOTE: THIS SPRING MUST NOT BE TIGHT.

(1 OF 4)

ADJUSTMENT INSTRUCTIONS FOR SHOPMASTER CUTTERS

ALIGNMENT OF CUTTERS ON THEIR TRACKS
(THIS SHEET IS TO BE USED WITH DWG. SMC82564)

1. PLACE FULL LENGTH SHEET OF METAL (120" - 10' UNIT AND 96" - 8' UNIT) AS SHOWN.
2. POSITION MAGNO-PAK "D" (ONLY) AS SHOWN.
3. START LENGTH CUTTER #1 INTO METAL AND AS IT IS MAKING THE CUT PLACE A THUMB ON BOTH THE SHEET AND THE SHOPMASTER TOP AT POSITION "E". (THIS WILL ALLOW THE OPERATOR TO FEEL IF THE METAL PUSHES OR PULLS, WHICH RESULTS IN BOWED CUTS.)
4. IF THE SHEET PULLS IN DIRECTION "X", PROCEED AS FOLLOWS:
 - A. LOOSEN LOCKNUTS ON "A" AND "B".

NOTE: (IT IS NECESSARY TO REMOVE LOWER FRONT SIDE CHAIN GUARD FOR ACCESS TO THE LOCKNUT ON BOLT "A".)
 - B. TURN BOLT "B" COUNTERCLOCKWISE ABOUT 1/8 TURN, AND TIGHTEN LOCKNUT.
 - C. ADJUST BOLT "A" UNTIL TENSION ON THE SPRING IS JUST ENOUGH TO RETURN THE CUTTER CASTING AGAINST BOLT "B". (PUSH CUTTER #1 IN DIRECTION "Z" ABOUT 1/4" FROM "B" TO CHECK TENSION ON THE SPRING.)

NOTE: IT IS NOT NECESSARY TO TIGHTEN THE LOCKNUT ON BOLT "A" UNTIL FINAL ADJUSTMENTS ARE MADE.
 - D. CUT ANOTHER STRIP OF METAL, USING THE SAME PROCEDURE AS ABOVE. IF THE SHEET STILL PULLS IN DIRECTION "X", KEEP MAKING ADJUSTMENTS UNTIL THE SHEET DOES NOT PULL AT POSITION "E".
 - E. AFTER THE FINAL ADJUSTMENTS HAVE BEEN MADE, TIGHTEN THE LOCKNUT ON "A" AND REPLACE GUARD. ALSO MAKE SURE THAT LOCKNUT ON "B" IS TIGHT.
- 4A. IF THE SHEET PUSHES IN DIRECTION "Y", FOLLOW THE ABOVE PROCEDURE BUT TURN BOLT "B" IN A CLOCKWISE DIRECTION.
5. CUTTER #2 SHOULD BE ADJUSTED IN THE SAME MANNER AS #1.

(2 OF 4)

CUTTER WHEEL ALIGNMENT

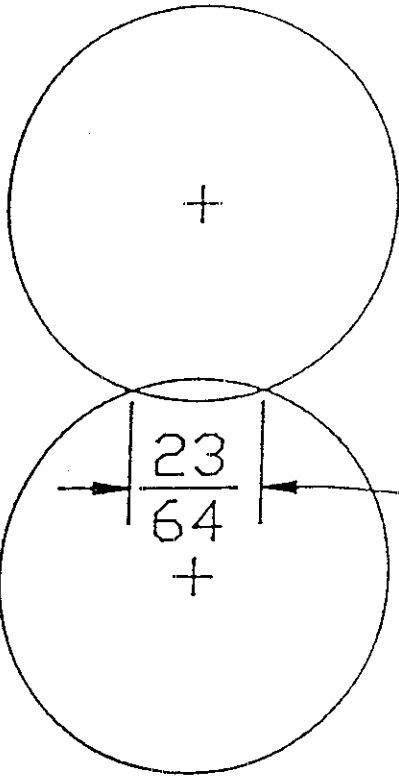

CORRECT OVERLAP OF
CUTTER WHEELS

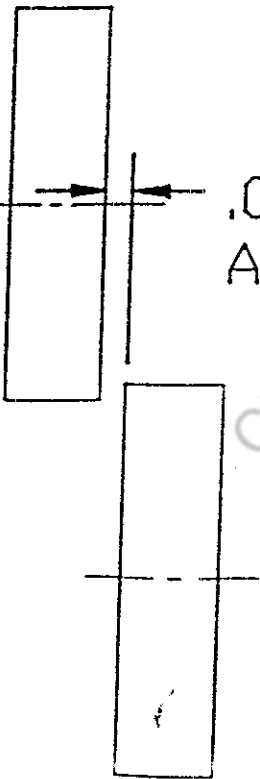

.002 CLEARANCE BETWEEN UPPER
AND LOWER CUTTER WHEEL

ENGEL INDUSTRIES, INC.
8122 REILLY AVE.
ST. LOUIS, MO. 63111

(3 OF 4)

PARTS LIST 10 FT. STANDARD NOTCHER

ITEM NO.	ENGEL PART NO.	NO. REQ'D.	DESCRIPTION	ITEM NO.	ENGEL PART NO.	NO. REQ'D.	DESCRIPTION
1	2095	1	Front Bed Plate	39	636	1	Die Handle
2	2109	1	Rear Bed Plate	40	7848	1	Depth Stop
3	1404	1	Front Bed Plate Stiffener	41		1	Socket Head Cap Screw 3/8-16 X 1" Lg.
4	1405	1	Rear Bed Plate Stiffener	42		2	Socket Head Cap Screw 1/2-20 X 2 1/2" Lg.
5	33	1	Beam Assembly	43		5	Socket Head Cap Screw 1/2-20 X 3/4" Lg.
6	6334	1	Die Lift Assembly	44		1	Hex Head Bolt 3/8-16 X 3/4
7	22	2	Leg Assembly	45		2	Hex Head Bolt 1/2-20 X 3/4
8	1292	4	Leg Spacers	46		1	Nut Jam 3/8-16
9	197	4	Leg Brace	47		1	Washer 3/8 S.A.E.
10	1402	1	Apron Assembly	48		1	Spring Pin 1/8 X 5/8 Lg.
11	178	3	Apron Brace				<u>PITTS. NOTCH 1 3/8" DEEP</u>
12	1347	1	Drive Shaft Hand Powered	33		1	Body
	189	1	Drive Shaft Motor Powered	34		1	Piston
	1407	1	Drive Shaft Air Powered	35		1	Piston Cover
13	177	2	Bearing Block	36		1	Die Plate - St. Side Pitts.
14	65	6	Bed Plate Spacers				Die Plate - R. & L. Center Pitts.
15	150	2	Truss Bar	37		1	Die Plate - R. & L. Side Shear Pitts.
16	1330	1	Truss Bar Jack Assembly				Punch - L.H. Pitts.
17	19	2	Beam Support w/Bunting #E-838				Punch - R.H. Pitts.
18	165	2	Eccentric Strap w/Bunting #H-5756	38		1	Shear Plate - Pitts.
19	163	2	Eccentric Strap Spacer	39		1	Die Handle
20	179	2	Eccentric Cam	40		1	Depth Stop
21	945	2	Spring Brake Assembly (Motor Powered Only)	41		1	Socket Head Cap Screw 3/8-16 X 1" Lg.
22	1254	1	Scale	42		2	Socket Head Cap Screw 1/2-20 X 2 1/2" Lg.
23	160	2	Scale End Support	43		5	Socket Head Cap Screw 1/2-20 X 3/4" Lg.
24	8	2	Scale Support Assembly	44		1	Hex Head Bolt 3/8-16 X 3/4
25	602	5	Die Assembly	45		2	Hex Head Bolt 1/2-20 X 3/4
26		2	Socket Head Cap Screw 5/8-11 X 2" Lg.	46		1	Nut Jam 3/8-16
27		4	Hex Head Bolt 1/2-13 X 2 1/2" Lg.	47		1	Washer 3/8 S.A.E.
28		4	Hex Head Bolt 1/2-13 X 1 1/2" Lg.	48		1	Spring Pin 1/8 X 5/8 Lg.
29		4	Hex Head Bolt 1/2-13 X 1 1/2" Lg.				<u>SPRING BRAKE ASSEMBLY (Motor Powered Only)</u>
30		12	Round Head Screw 3/8-16 X 3/4" Lg.	49		1	Adj. Pipe
31		10	Flat Head Screw 1/2-20 X 3/4" Lg.	50		1	Adj. Plate
32		3	Washer 5/8 S.A.E.	51		1	Adj. Plunger
		2	"Y" NOTCH 1 3/8" DEEP	52		1	Spring
				53		1	Grease Fitting
33	7940	1	Body (Casting)	54		1	Hex Head Bolt 1/2-13 X 1 1/2" Lg.
34	8024	1	Piston	55		1	Hex Head Nut 1/2-13 Jam
35	7929	1	Piston Cover				
36	7950	2	Die Plates "Y"				
37	7954	1	Punch "Y"				
38	7923	1	Shear Plate "Y"				

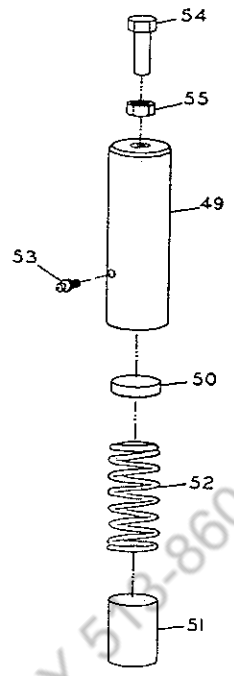

SPRING BRAKE ASSEMBLY

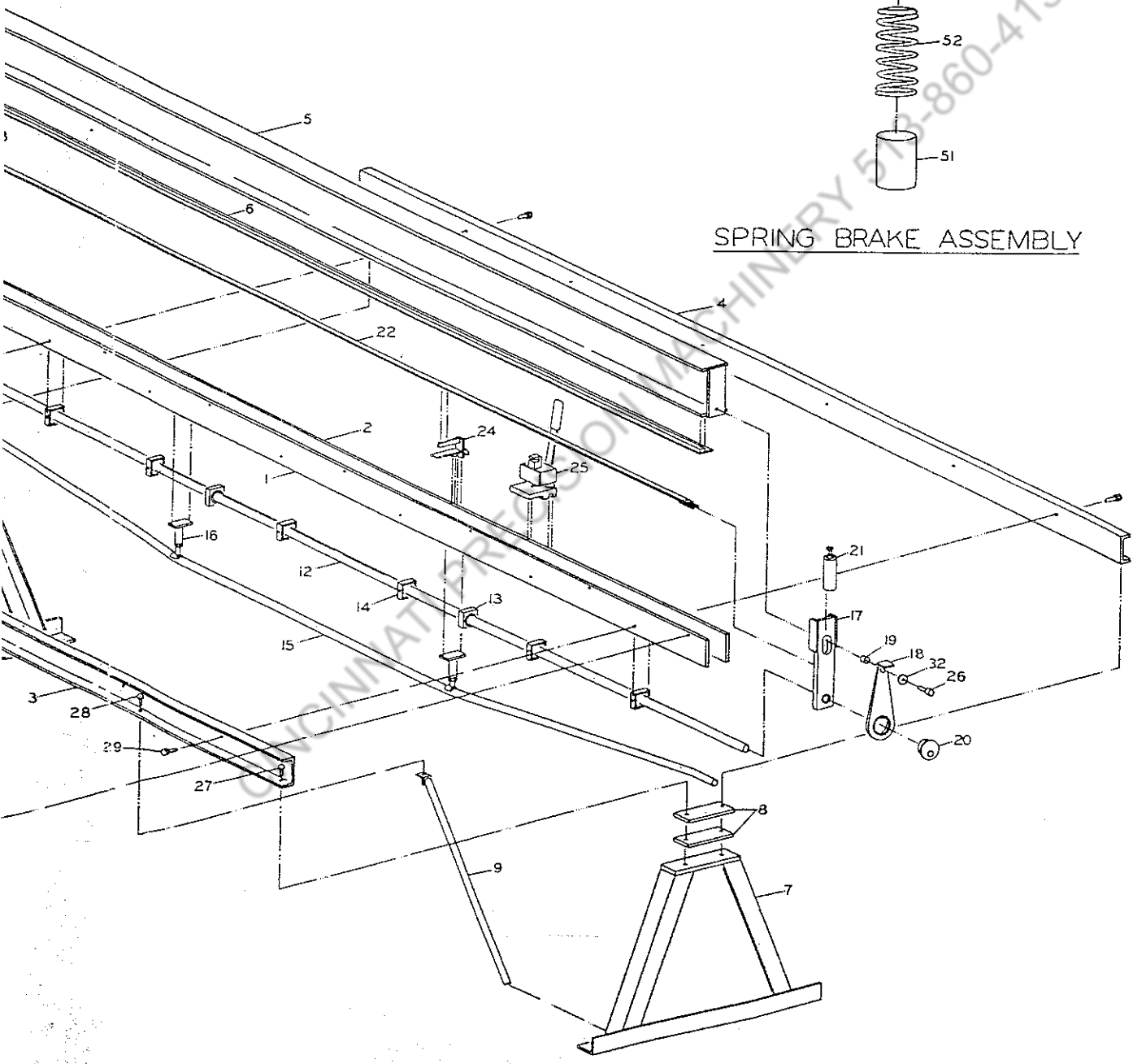

STANDARD NOTCHER

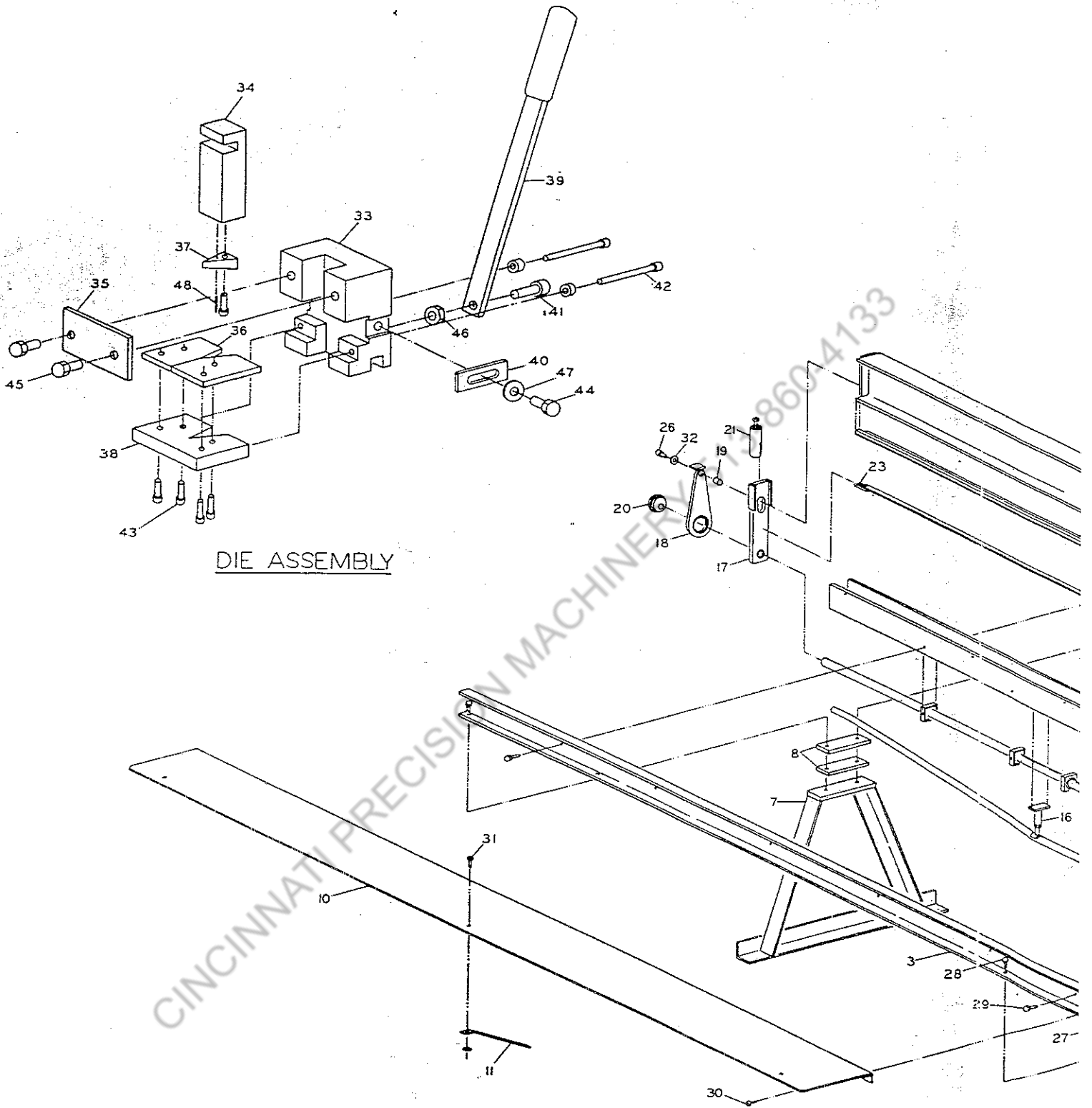

DIE ASSEMBLY

CINCINNATI PRECISION MACHINERY 860-4133