

Connecticut

PLAIN BENCH BRAKE MODEL 422

OPERATIONS MANUAL AND PARTS LIST

Set the brake on a level bench and shim under the feet until it rests evenly and will not rock. Fasten to bench with large screws.

Connecticut Bench Brakes are rated according to the catalog capacity for a full length bend in mild steel at least 3/8" from the edge of the sheet. An adjustment of 1/8" is provided in the position of the beam for material thickness and radius of bend. This is controlled by eccentric pins No. 66 and locking set screws at the rear of the machine, each end. There should be clearance of at least one and one-half times the thickness of material between the apron and edge of beam, when the apron is at the 90 degree position. For bending stainless steel, reduce the capacity by 4 gages.

The work is clamped between the Bed and Beam by means of Eccentric Levers No. 26. To make a bend, raise the apron handles to the desired angle. The notches at the ends of the apron and beam are for clearance when a sheet is flanged along one edge and then bent at right angles to the flange.

Clamping pressure is controlled by nuts No. 45. This pressure should be adjusted with a small piece of the material to be bent clamped in each end of the machine. Move the nuts so that the levers No. 26 pull against the stops with an equal effort. Excessive clamping pressure is not required. Use only enough to hold the material firmly in the Brake.

These Brakes are not intended for bending rods, wires, multiple thicknesses or across lock seams. Operations of this type will result in denting the edge of the Apron and springing the machine out of line.

Lubricate the moving parts of the machine with light grease or heavy oil. Lasting accuracy depends on proper lubrication.



ROPER WHITNEY OF ROCKFORD, INC.

2833 HUFFMAN BLVD., ROCKFORD, ILLINOIS 61103-3990 * 815/962-3011 * FAX 815/962-2227

Website: www.roperswhitney.com * Email: info@roperswhitney.com

422 PLAIN BENCH BRAKE
PARTS CHART

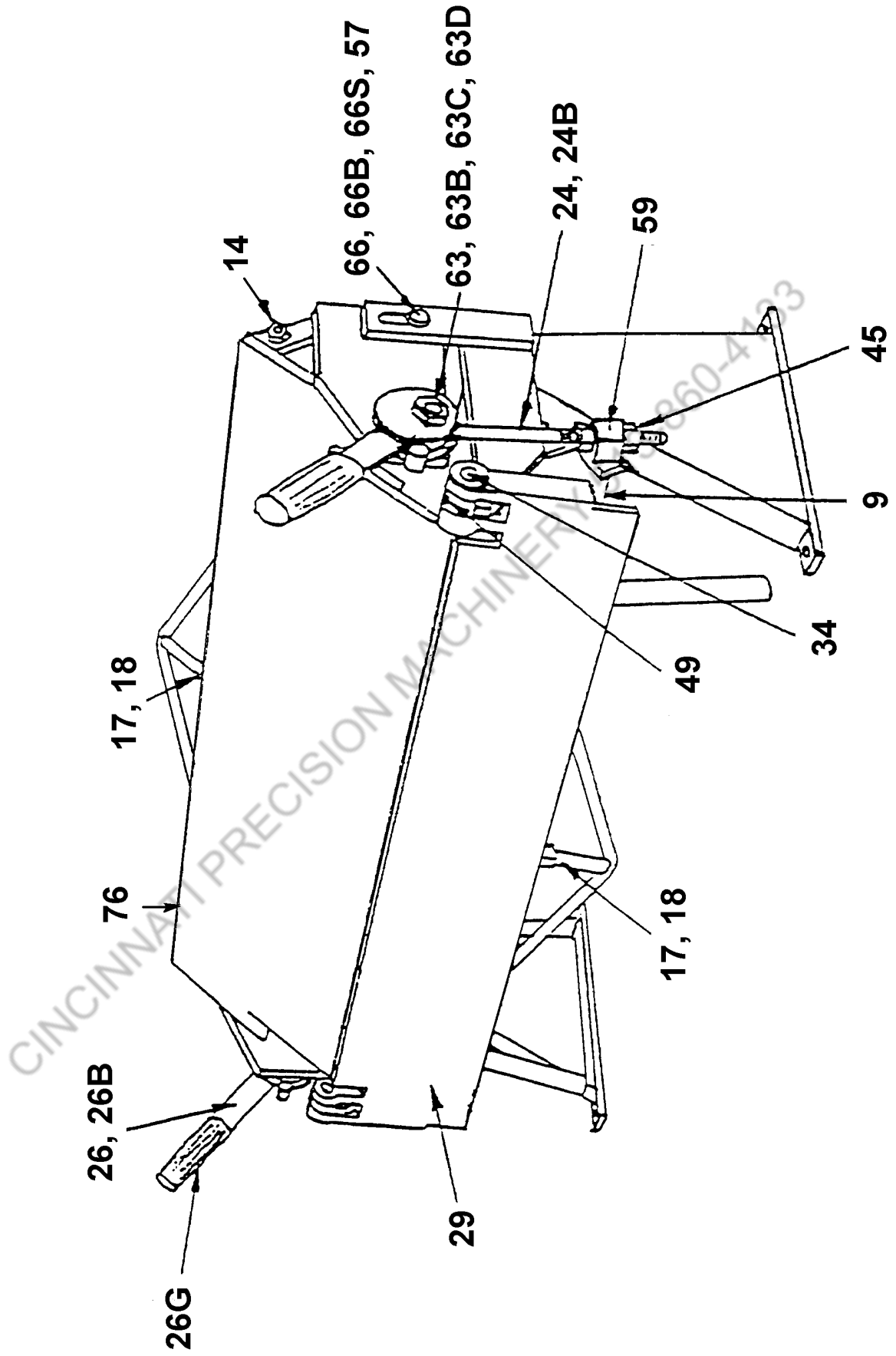

**MODEL 422 PLAIN BENCH BRAKE
PARTS LIST**

ITEM NO.	PART NO.	PART NAME
9	Consult Factory	Bed Assembly
14	643023007	Tie Rod Nut
17	457160098	Strap Bolt
18	643023007	Strap Nut
24	757860022	L.H. & R.H. Toggle Assembly
24B	757080020	Toggle Bushing - 2"
26	757030024	Eccentric Assembly with R.H. Bushing
26	757030025	Eccentric Assembly with L.H. Bushing
26B	757080023	Eccentric Bushing - 1"
27G	633356335	Handle Grip
29	Consult Factory	Apron Assembly
34	757160083	Hinge Pin
45	643023007	Toggle Nut
49	621012083	Set Screw
57	656164301	Snap Ring
59	757160030	Lower Toggle Pin
63	657000388	Clamping Collar
63B	657245116	Thrust Bearing
63C	679033109	Lock Washer
63D	678033109	Flat Washer
66	757160031	Eccentric Slide Pin
66B	757080039	Slide Pin Bushing
66S	621012083	Slide Pin Set Screw
76	Consult Factory	Beam Assembly

CINCINNATI PRECISION MACHINERY 513-860-4133