

NO. 612 COMBINATION BENDING BRAKE

OPERATIONS MANUAL

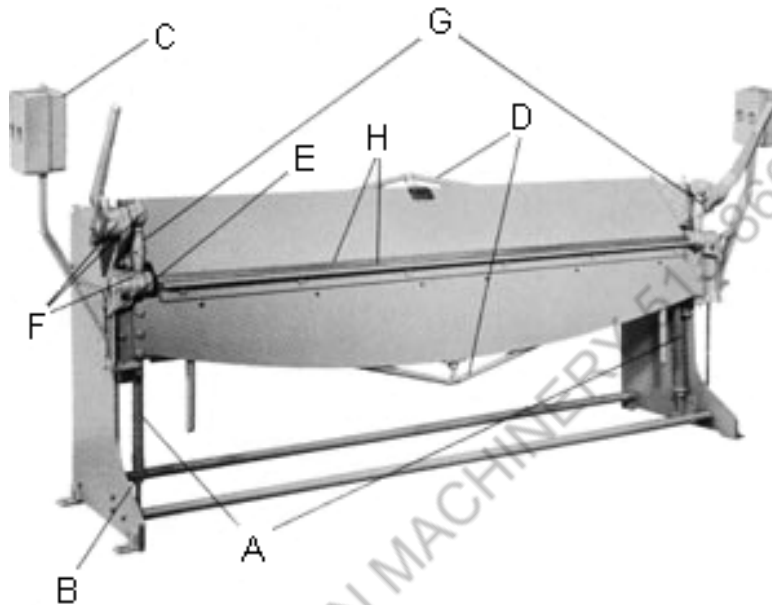

- A. Heavy-duty lower beam spring
- B. Spring adjustment nut
- C. Adjustable counterweight
- D. Heavy-duty truss rods
- E. Adjustable apron angle gauge
- F. High quality roller bearings
- G. Clamping pressure adjustments
- H. Removable upper & lower jaws



ROPER WHITNEY OF ROCKFORD, INC.

2833 HUFFMAN BLVD., ROCKFORD, ILLINOIS 61103-3990 * 815/962-3011 * FAX 815/962-2227

Website: www.roperwhitney.com * Email: info@roperwhitney.com

NO. 612 OPERATIONS MANUAL

CARE: Occasional oiling of moving parts with machine oil will ease operation and extend the life of the brake. Occasionally check and tighten the lower beam bracket gib screws (see figure 1) at each end of the brake. These screws are accessible when the apron is raised. These should be kept snug to reduce excess front to back play in the lower beam.

CAUTION: Do not form wire, nails, rods or pipe in these brakes. These brakes will form a 1" flange over the entire length in their rated capacity.

Brakes are reduced in capacity by 2 gauges when:

1. Apron angle iron work support (see figure 2) is removed.
2. Box fingers are used.

Brakes are reduced in capacity by 4 gauges when:

1. Apron angle iron work support and apron filler plate are removed.
2. Brake is used on stainless steel.

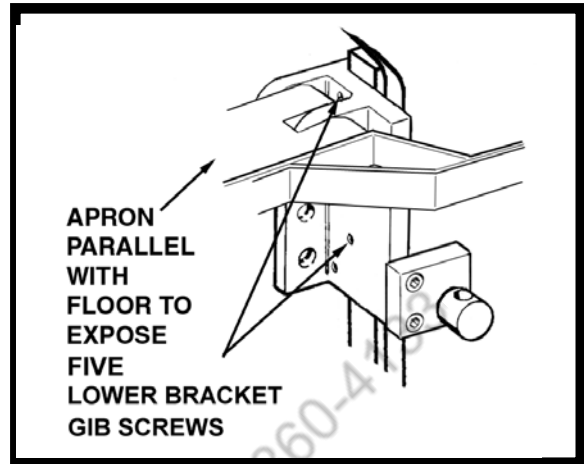

Figure 1. Lower Beam Bracket Gib Screws

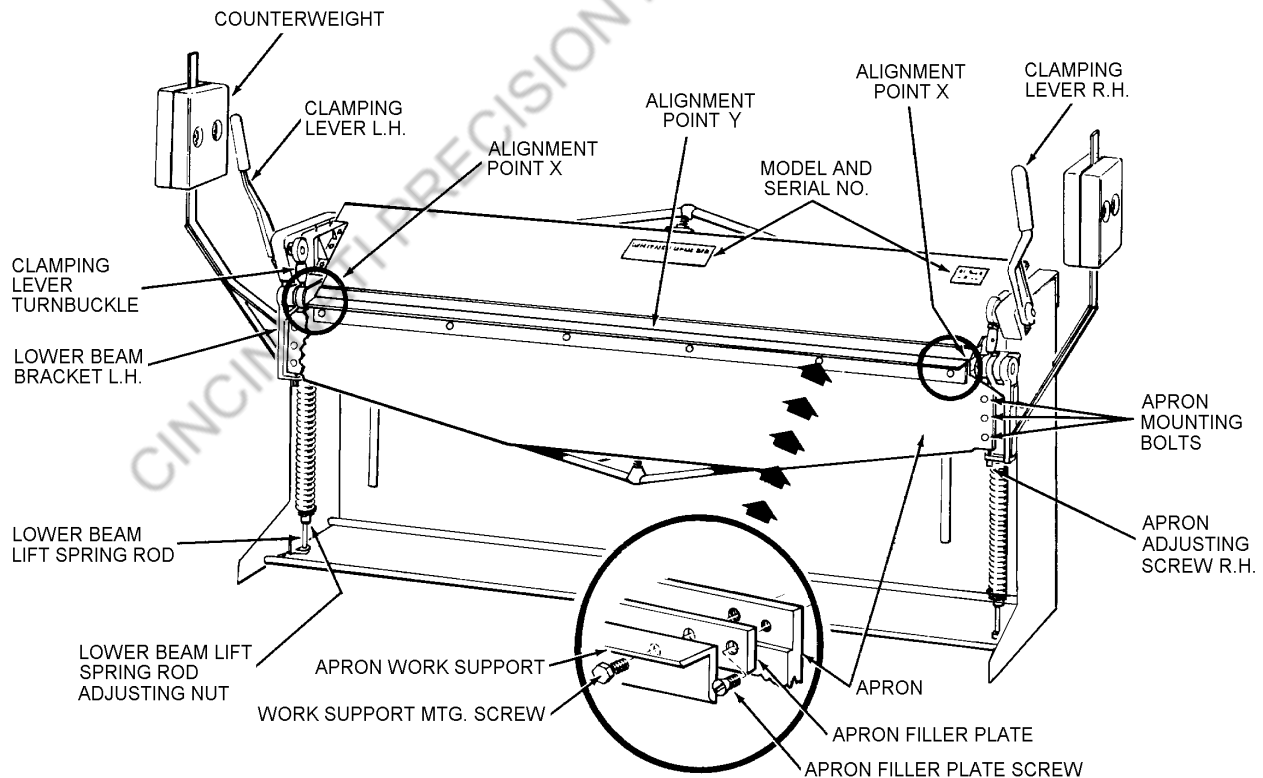

Figure 2. Front View of Brake

NO. 612 OPERATIONS MANUAL

ADJUSTMENTS - BEFORE OPERATION

1. Apron must be flush with lower beam jaw before beginning operation. To adjust loosen apron mounting bolts slightly and turn apron adjusting screws as necessary. After adjustment, retighten apron mounting bolts. If alignment cannot be achieved, follow major brake alignment procedure following.

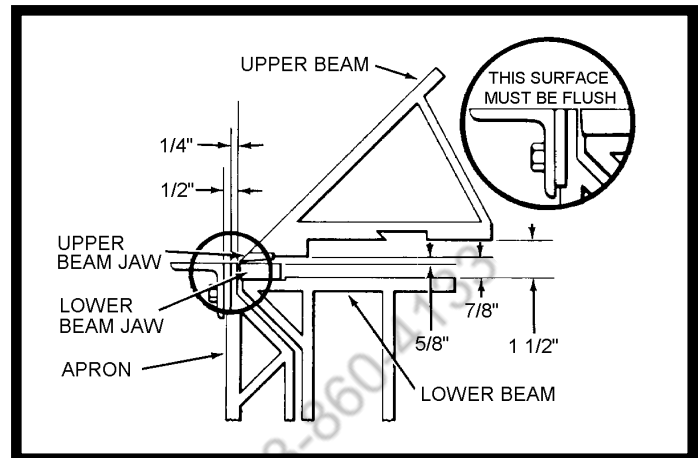

Figure 3. Reference Dimensions

CLAMPING PRESSURE ADJUSTMENT:

2. Check gauge of material to be formed to be sure it is within rated capacity of your brake. Place small sample of work piece on Lower Beam Jaw and clamp in position by moving the Clamping Lever forward. Sample should now be held firmly in position. To adjust for more or less clamping pressure, move Clamping Lever to unlocked (up) position, loosen the Clamping Lever Turnbuckle Lock Nut (figure 4) on both ends of brake and adjust the Clamping Lever Turnbuckles as necessary to achieve firm clamping pressure. Retighten the lock-nuts.

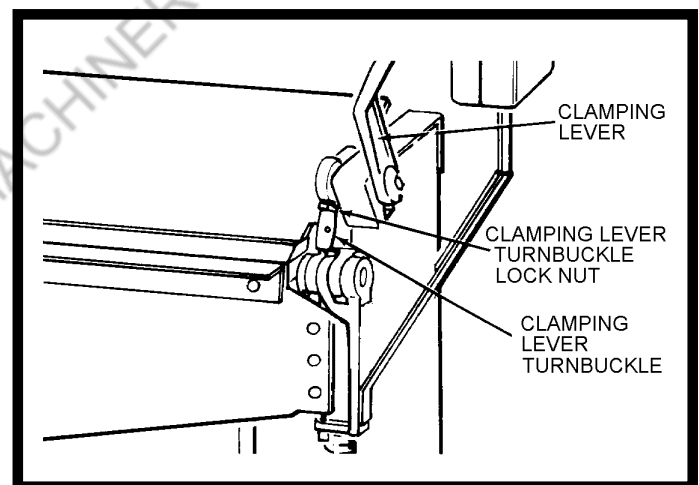

Figure 4. Regulating Clamping Pressure

THICKNESS OF MATERIAL ADJUSTMENT:

3. Loosen the Upper Beam Slide Clamping Screws (figure 5) and Upper Beam Adjusting Screw Lock Nuts at both ends of brake. Set entire front edge of Upper Beam Jaw back from the Lower Beam Jaw the thickness of the metal to be bent by turning the Upper Beam Adjusting Screws back as necessary. Retighten all screws and nuts.

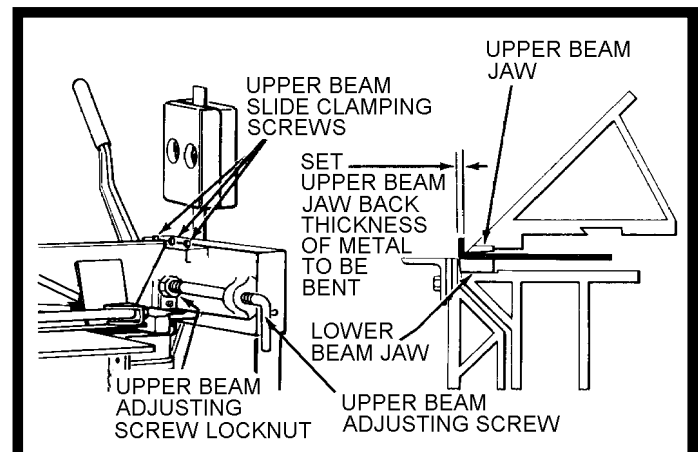

Figure 5. Adjustment of Brake Jaws for Material Thickness

NO. 612 OPERATIONS MANUAL

ADJUSTMENTS - FINE ALIGNMENT:

1. A sample work piece, the entire length of the brake, should be clamped in place. Make a test bend by lifting the Apron a full 90°. Release metal from brake jaws and check for straightness.

2. **ADJUSTMENTS FOR BOWING:** (Refer to figure 7 for location of Truss Nuts).



PROBLEM: Bows up.

SOLUTION: Release tension on Truss Nut (B).



PROBLEM: Bows down.

SOLUTION: Tighten Truss Nut (B). Level the Apron with the Lower Beam Jaw (see figure 3).

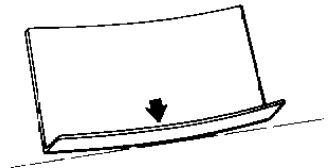

PROBLEM: Bows toward operator.

SOLUTION: Release some tension on Truss Nut (A) (depending on your brake).

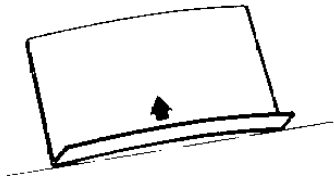

PROBLEM: Bows away from operator.

SOLUTION: Tighten Truss Nut (A) (depending on your brake).

3. **ADJUSTMENT FOR UNEVEN ANGLE OF BEND:**

If 90° sample bend is true at both ends but less than 90° at center of piece, loosen Apron Mounting Bolts (figure 2) and lower the Apron approximately 1/32" by unscrewing the Apron Adjusting Screws. Retighten the Apron Mounting Bolts and tighten Truss Nut (C, figure 7) until both jaws of brake are flush at brake center (see figure 3).

INCREASING JAW OPENING:

The opening between the brake jaws may be increased to a maximum of 1 5/8". With the Clamping Levers in the unlocked position, turn the Lower Beam Lift Spring Rod Adjusting Nut (figure 2) at each end of brake downward until the desired opening is obtained.

CAUTION:

The lower beam lift springs support the weight of the entire lower beam assembly when the brake is unclamped. Always adjust the lower beam spring adjusting nuts with the brake in the unclamped position. If adjusted with the brake in the clamped position the beam, when unclamped, will drop rapidly downward causing the clamping handles to snap backwards.

NO. 612 OPERATIONS MANUAL

MAJOR BRAKE ALIGNMENT:

Follow the procedure listed below if brake is badly out of alignment. A 30" length of one inch pipe will help attain necessary leverage when applied to the end of the wrench supplied with the brake.

1. Loosen all Truss Nuts (A, B, C, E, figure 7)
2. Tighten Truss Nut (B) until snug. Tighten an additional three complete turns.
3. Check Apron at the alignment points (X, figure 2) to see if it is flush with top of Lower Beam Jaw (see inset, figure 2). Up and down movement of the Apron is controlled by turning the Apron Adjusting Screw (figure 2) at each end of the Apron.
4. Tighten Truss Nut (C, figure 7) until Apron is flush with Lower Beam Jaw at alignment point (Y, figure 2).
5. Tighten Truss Nut (E, figure 7) as tight as possible.
6. Tighten Truss Nut (A) until the Upper Beam Jaw is straight and parallel in relation to the Lower Beam Jaw.

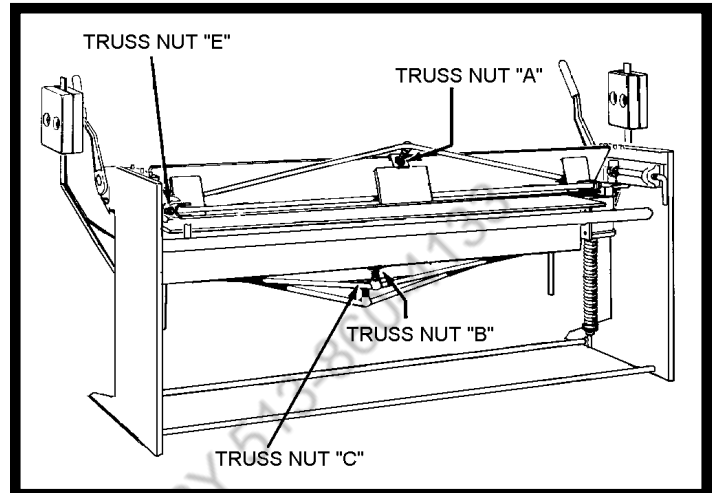

Figure 7. Rear View of Brake Showing Tension Adjustment Points

NO. 612 OPERATIONS MANUAL

STRAIGHT BENDING:

Set Upper Beam Jaw back to thickness of metal to be bent. (See figure 5). Bends up to 135° may be achieved by raising the Apron until the desired angle of the bend is obtained. (See figure 8).

FLATTENED SEAM BENDING:

Bend metal to full 135° angle as explained above (figure 8). Remove metal from between the jaws and reposition it against the Upper Beam as shown in figure 9. Lift Apron to flatten seam.

JOINTING:

Bend metal piece to full 135° angle. Remove metal from between the jaws and reposition it against the Upper Beam in same manner as explained above. Lift Apron to complete bend. Do not flatten seam; but, allow for thickness of metal piece to be jointed.

The Roper Whitney No. 9 Button Punch Tool may be used to lock the two pieces together securely.

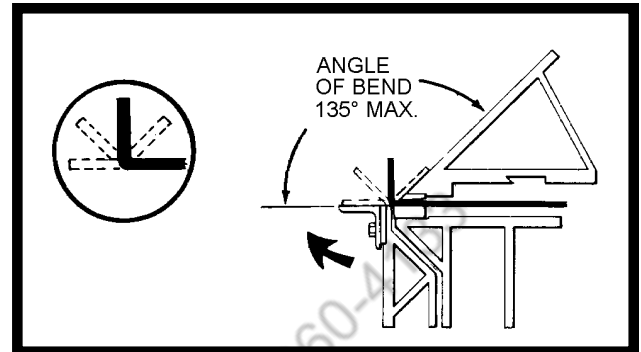

Figure 8. Straight Bending

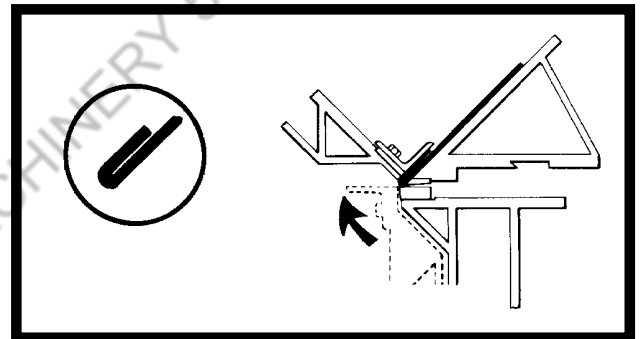

Figure 9. Flattened Seam Bending

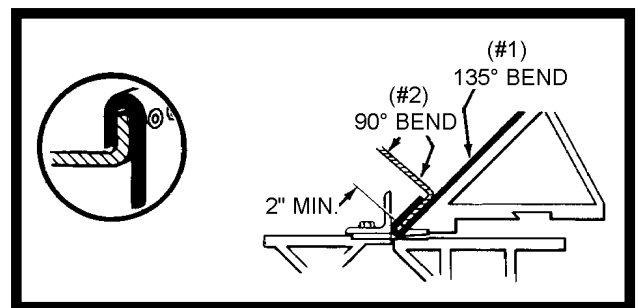

Figure 10. Jointing Two Metal Pieces

NO. 612 OPERATIONS MANUAL

MINIMUM REVERSE BENDING:

Remove Apron Angle Iron Work Support and Apron Filler Plate (inset, figure 2). This permits 1/4" reverse bends to be made on all brakes except Model Nos. 812, 1012, and 1214 will make a reverse bend of 3/8".

NOTE:

When the Apron Angle Iron Work Support and Apron Filler Plate is removed, the brake capacity is reduced by 4 gauges.

To accomplish a minimum reverse bend, a metal lip is first bent to a 90° angle. Metal piece is removed and repositioned between the jaws as shown in Step 1 (figure 11). Raise Apron 90° to complete bend, Step 2 (figure 10).

REPEAT BENDS:

Repeat bends can be made easily by using the apron gauge illustrated in figure 12. Make the first bend to the desired degree and clamp apron gauge bar stop collar using set screw in position. Apron will contact stop and insure accurate repeatability of bend.

TINNER'S MOULDING FORMS:

One set of five standard sizes of Tinner's Mould; 5/8", 1", 1 5/8", 2 1/2", and 3" is available for all sizes of Combination Bending Brakes. Remove the Apron Angle Iron Work Support and position the forming mold on the lip of the Apron (see figure 13). Use a hammer to tap the moulding form clamps through the holes in the Apron of the brake. Metal piece part is wiped over the moulding form manually to obtain desired radius.

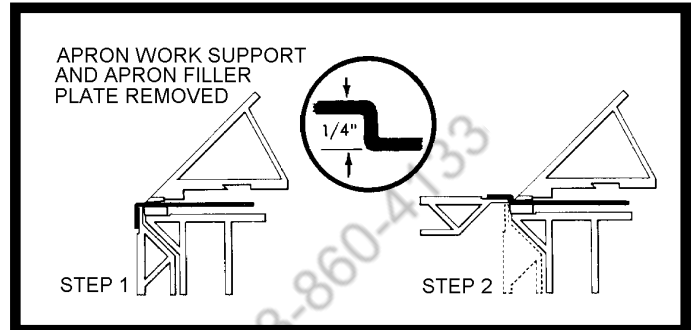

Figure 11. Minimum Reverse Bending

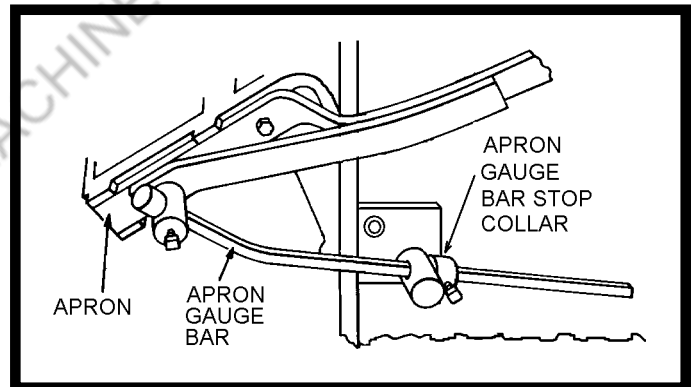

Figure 12. Apron Gauge

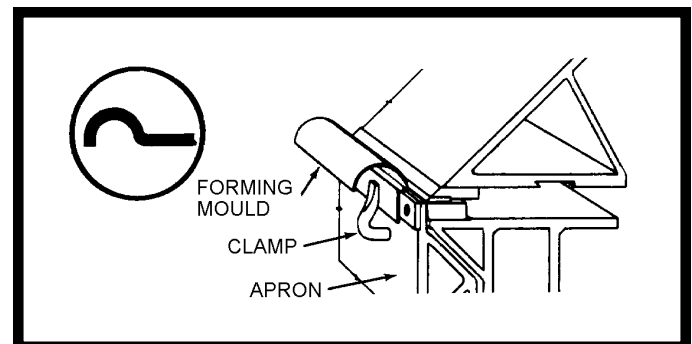

Figure 13. Standard Tinner's Forming Mould

NO. 612 OPERATIONS MANUAL

RADIUS FORMING:

Radius Former Bars are available for all sizes of Combination Bending Brakes. These bars are available in sizes from $\frac{3}{32}$ " to 1" in increments of $\frac{1}{32}$ ". Sizes 1", 1 $\frac{1}{2}$ ", 2", and 2 $\frac{1}{2}$ " are available. The number of Radius Holder Fingers required depends upon the length of the brake; 3 Holder Fingers are required for a 4 foot brake, 4 are required for a 6 foot brake, 5 are required for an 8 foot brake, and 6 for a 10 foot brake. Holder Fingers are all alike for all brake lengths. Shorter Radius Former Bars may be installed on longer brakes if desired.

INSTALLING RADIUS FORMER BARS:

1. Assemble the necessary number of Radius Finger Holders to the Radius Forming Bar as shown in figure 14.
2. Increase the distance between the brake jaws by turning the Lower Beam Lift Spring Rod Adjusting Nut (figure 2) at each end of brake downward as far as it will go.

CAUTION:

The lower beam lift springs support the weight of the entire lower beam assembly when the brake is unclamped. Always adjust the lower beam spring adjusting nuts with the brake in the unclamped position. If adjusted with the brake in the clamped position the beam, when unclamped, will drop rapidly downward causing the clamping handles to snap backwards.

3. When using a 1 $\frac{1}{2}$ " or larger Radius Forming Bar, an Auxiliary Lower Beam Jaw is required and should be inserted in position behind the lower Beam Jaw (figure 15).
4. Loosen the Upper Beam Slide Clamping Screws (figure 5) and Upper Beam Adjusting Screw Lock Nuts at both ends of brake. Move the entire Upper Beam back far enough to accommodate the assembled Radius Former Finger and Bar (figure 15).

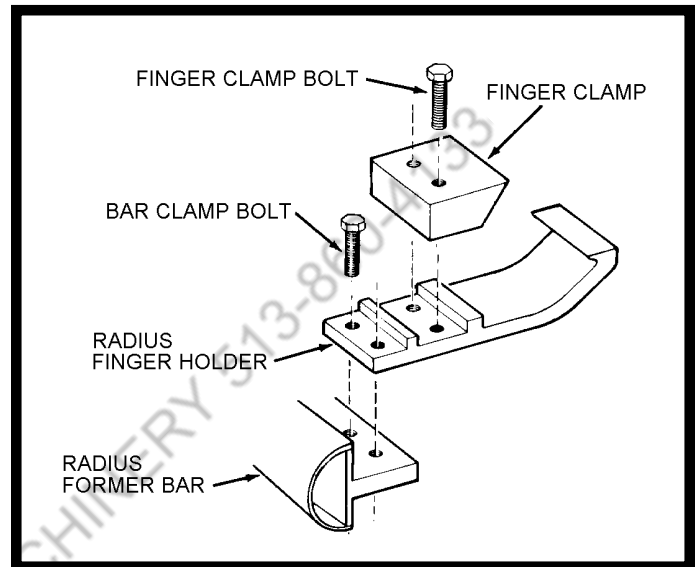

Figure 14. Assembling Radius Formers

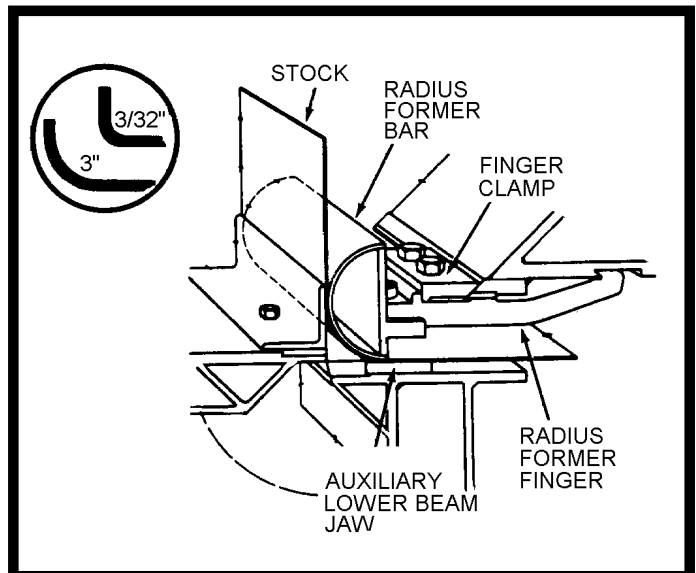

Figure 15. Radius Bending

NO. 612 OPERATIONS MANUAL

5. Loosen Finger Clamp Bolts and hook Holder Finger into dove tail in Upper Beam. Position lip of Clamp over Upper Beam Jaw and tighten Finger Clamp Bolts securely.
6. Move Upper Beam back or forward as necessary until front edge of Radius Former Bar is back from the Lower Beam Jaw the thickness of the metal to be bent. (see figure 15). Tighten all Upper Beam Slide Clamping Screws and Adjusting Screw Lock Nuts.
7. With Clamping Lever in unlocked (up) position, adjust Clamping Lever Turnbuckles (figure 4) and Lower Beam Lift Spring Rod Adjusting Nuts as necessary to obtain desired clamping pressure. Pressure should be firm enough so metal will not slip when clamped.

CAUTION:

The lower beam lift springs support the weight of the entire lower beam assembly when the brake is unclamped. Always adjust the lower beam spring adjusting nuts with the brake in the unclamped position. If adjusted with the brake in the clamped position the beam, when unclamped, will drop rapidly downward causing the clamping handles to snap backwards.

BOX AND PAN BENDING:

Box Fingers are available for all Combination Bending Brakes in widths from 1" through 6" in increments of 1/2", and an 8" width. They are made in 6" and 8" depths. The size and number of Box Fingers required can easily be determined as follows:

1. Largest dimension of box or pan determines the quantity of Box Fingers required.
2. Depth of box or pan determines the Box Finger depth.

Example: To make a box 10" wide x 15" long x 7" deep; use 8" deep Box Fingers in following combinations:

2-4" wide Box Fingers (or 1-8" wide)

1-2" wide Box Finger

10" bend can now be made.

Add 1-5" wide Box Finger

15" bend can now be made.

Any combination of Box Fingers that add up to the required total may be used.

INSTALLING BOX FINGERS:

With Clamping Lever in unlocked position, proceed as follows:

1. Turn Lower Beam Lift Spring Rod Adjusting Nuts (figure 2) down to bottom at both ends of brake.
2. Loosen all Upper Beam Slide Screws and Upper Beam Adjusting Screw Lock Nuts. Move Upper Beam to the rear by turning Upper Beam Adjusting Screws back to accommodate either 6" or 8" depth fingers.

NO. 612 OPERATIONS MANUAL

3. Open Clamping Lever Turnbuckles (figure 4). A rod may be inserted through holes in Turnbuckles for ease in turning.
4. Loosen Finger Clamp Bolts (figure 16) and hook finger into dove tail of Upper Beam. Position lip of Clamp over Upper Beam Jaw and tighten Finger Clamp Bolts securely.
5. Move Upper Beam back or forward as needed so that finger bending nose is 1/64" back from front edge of Lower Beam Jaw (figure 17). Use Upper Beam Adjusting Screws (figure 5)
6. Tighten Upper Beam Slide Clamping Screws and Upper Beam Adjusting Screw Lock Nuts.
7. Adjust Clamping Lever Turnbuckles and Lower Beam Lift Spring Rod Adjusting Nuts to attain proper clamping pressure. Pressure should be firm enough so metal will not slip when clamped.

NOTE: When using partial quantities of fingers, always mount fingers in the middle of brake to equalize strain. When bending with fingers, capacity is 2 gauges lighter. A 14 gauge brake with Box Fingers installed will handle 16 gauge or lighter material only.

FINGER ALIGNMENT:

If bottom of Box Fingers are not flush, align as follows:

1. Choose a 4" to 6" width finger and set the Finger Leveling screws (figure 16) until end of each screw protrudes 1/64" above mounting surface of the finger. Lock the screws in this position by securely tightening Finger Leveling Lock Nuts.
2. This finger is now the master finger and should be mounted in the center of the Upper Beam. Be sure that finger is square when tightening Finger Clamp Bolts. All other fingers are now adjusted to this master finger.
3. Set Finger Leveling Screws of remaining Box Fingers approximately the same as master finger. Mount finger on brake on right side of master finger. Do not allow side of finger to touch side of master finger (allow about 1/32"). Tighten Finger Clamp Bolts and check to see if bottom of finger is flush with bottom of master finger. Adjust up or down as required by turning Finger

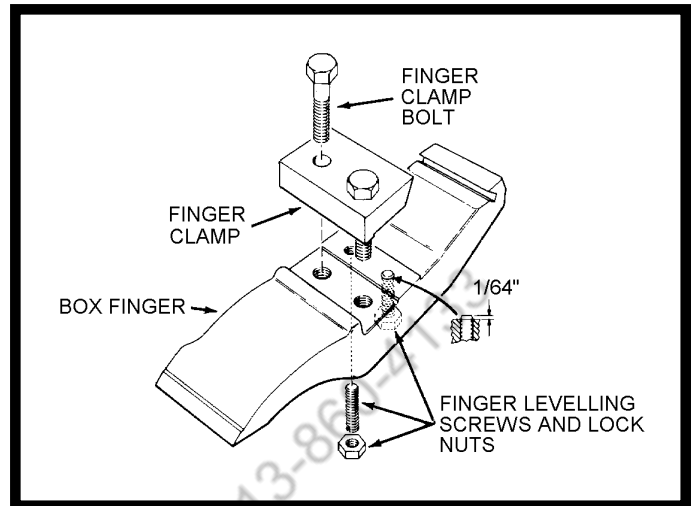

Figure 16. Box and Pan Finger

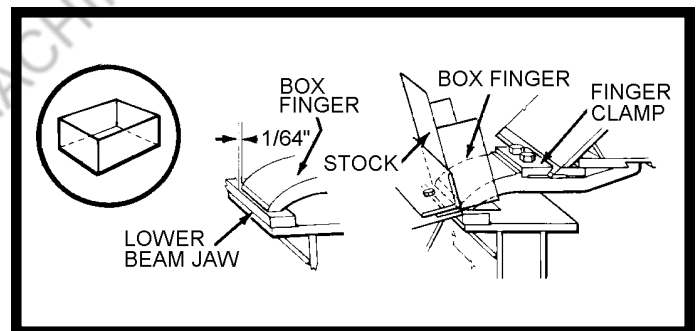

Figure 17. Box and Pan Bending

NO. 612 OPERATIONS MANUAL

Leveling Screws in or out. This can be done from rear of brake while finger is clamped in place. Finger Clamp bolts may require slight loosening at times while Finger Leveling Screws are turned. Be sure Finger Clamp Bolts are securely tightened before checking new adjustment.

4. When adjustment is correct, remove finger and remount on left side of master finger and check again. If bottom edges are not level, correct as in step 3. Tighten Finger Leveling Lock Nuts securely.
5. Remove this finger and set aside. Then proceed to adjust all other fingers in the same manner.
6. When all fingers have been adjusted to master finger, they may be assembled on nose of brake in any combination and they will all align with each other.

UPPER BEAM ASSEMBLY PARTS IDENTIFICATION CHART

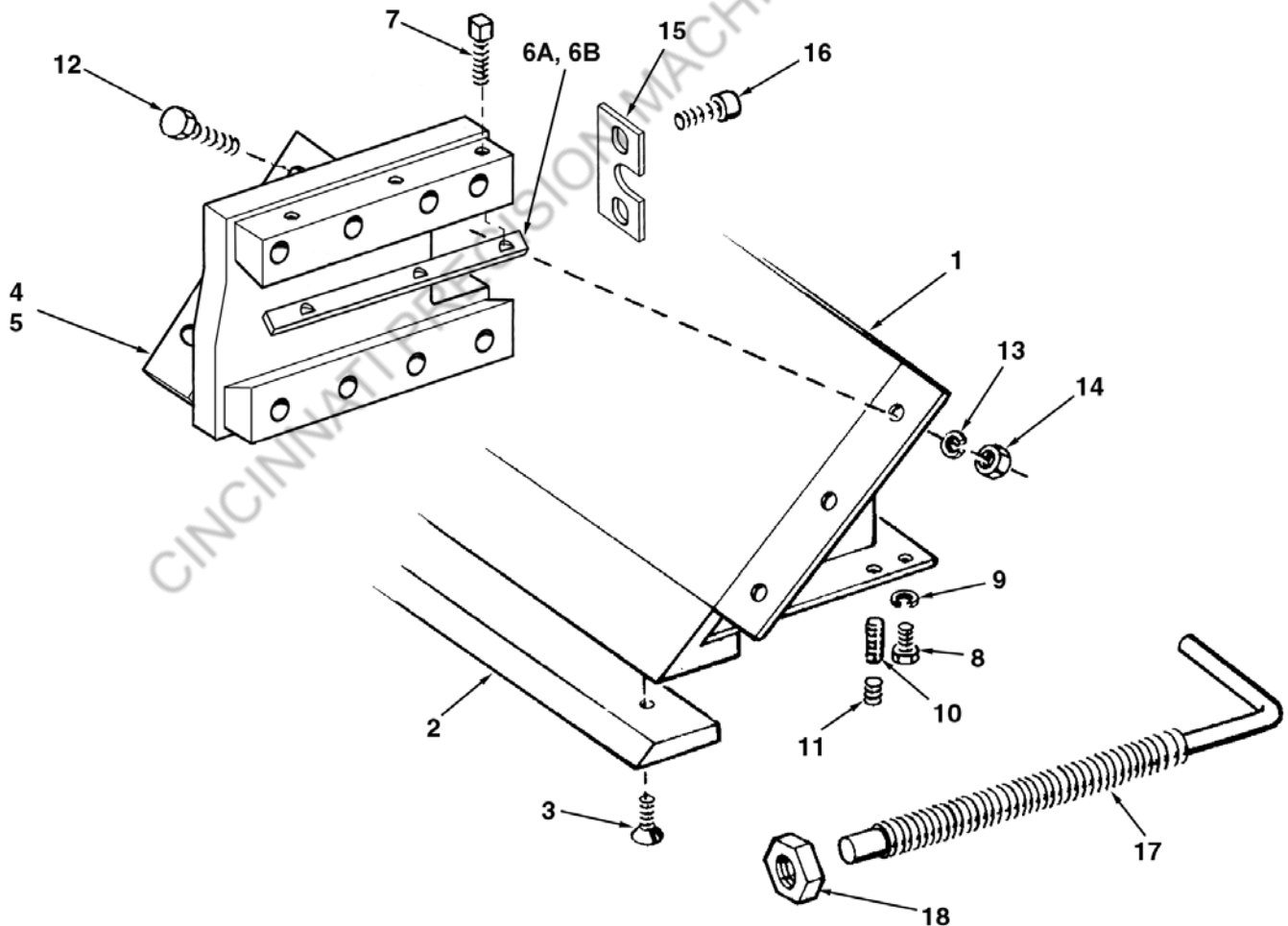

NO. 612
UPPER BEAM ASSEMBLY
PARTS IDENTIFICATION LIST

ITEM NO.	PART NAME	PART NO.	OLD PART NO. (Ref. only)	QTY.
1A	Upper Beam Complete (consists of items 1-14)	756020377	612-1M	1
1	Upper Beam	Available only as assembly 756020377 above		1
2	Upper Beam Jaw	756020379	616-5R	1
3	Upper Beam Jaw Mounting Screws 5/16-18 x 5/8 Flat Head Socket Cap	613012130	WS2528	13
4	Upper Beam Slide, RH	756730355	412-6	1
5	Upper Beam Slide, LH	756730356	412-7	1
6A	Upper Beam Slide Gib, RH	756400357	412-15	1
6B	Upper Beam Slide Gib, LH	756400358	412-15	1
7	Upper Beam Slide Set Screws 1/2-13 x 1 3/4 Square Head	633012277	WS657	6
8	Upper Beam Bottom Plate Screw 1/2-13 x 1 3/4 Hex Head	601012277	WS66	6
9	Upper Beam Bottom Plate Screw Washer 1/2 Lock	679033107	WS1731	6
10	Bottom Adjusting Screw 3/8-16 x 3/4 Socket Set Screw	621012173	WS848	8
11	Bottom Adjusting Screw Lock Screw 3/8-16 x 3/16 Socket Set	656012621	WS1926	8
12	Upper Beam to Slide Mounting Screw 5/8-11 x 1 3/4 Hex Head	601012369	WS93	6
13	Upper Beam to Slide Mnt. Screw Lock Washer 5/8 Lock	679033109	WS1733	6
14	Upper Beam to Slide Mounting Screw Nuts 5/8-11 Nut Hex Full	643023009	WS1358	6
15	Upper Beam Adjusting Screw Plates	756060263	416-29	6
16	Upper Beam Adj. Screw Plate Mnt. Screws 3/8-16 x 3/4 Hex Head	601012173	WS31	4
17	Upper Beam Adjusting Screw	756650261	416-35	2
18	Upper Beam Adjusting Screw Nut	756560262	416-67	2

NO. 612
LOWER BEAM ASSEMBLY
PARTS IDENTIFICATION CHART

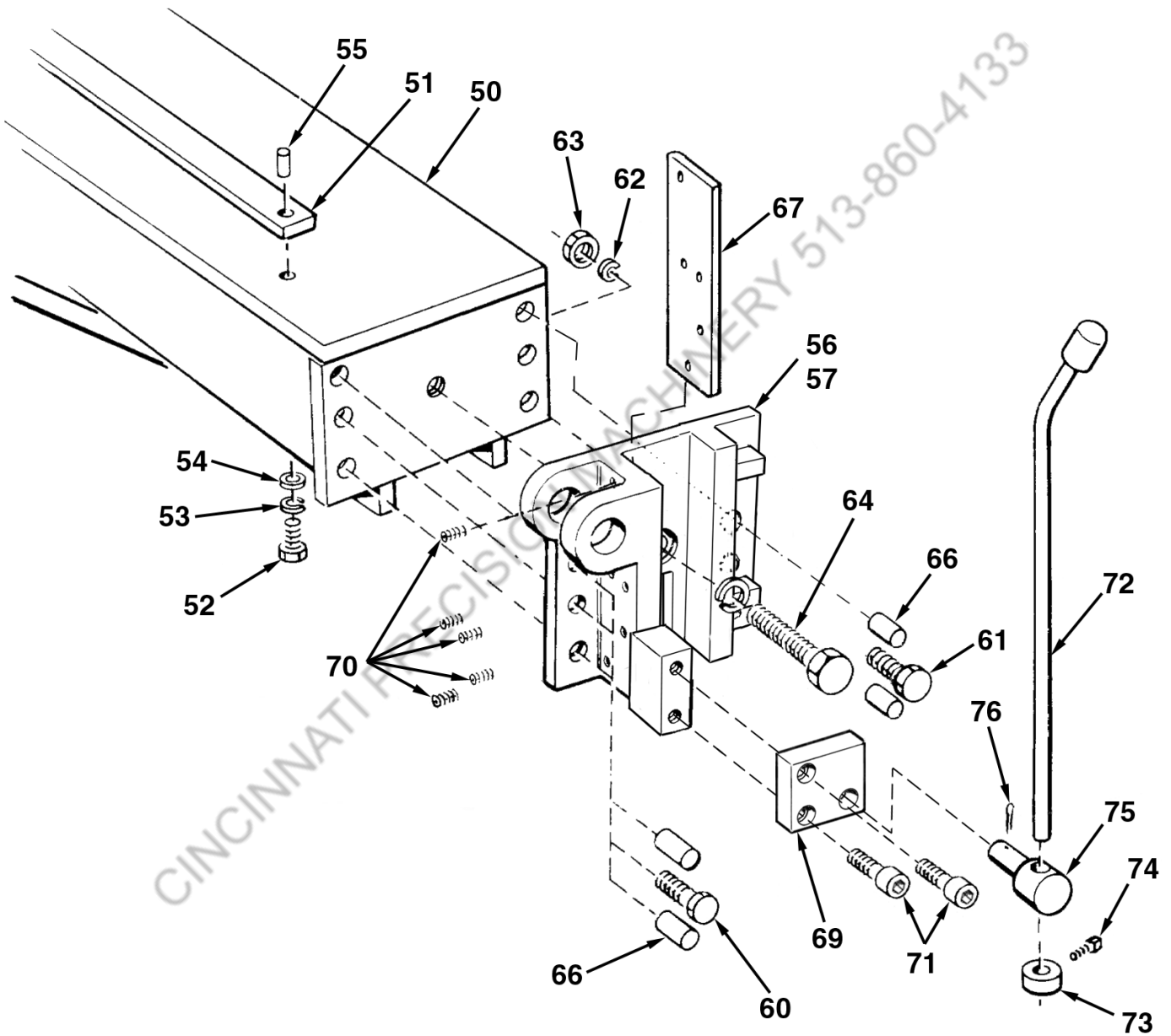

NO. 612
LOWER BEAM ASSEMBLY
PARTS IDENTIFICATION LIST

ITEM NO.	PART NAME	PART NO.	OLD PART NO. (Ref. only)	QTY.
50	Lower Beam	756020380	612-2M	1
51	Lower Beam Jaw	756020386	616-7	1
52	Lower Beam Jaw Mounting Screw 5/16-18 x 1 1/8 Hex Head	601012134	WS153	13
53	Lower Beam Jaw Mnt. Screw Lock Washer 5/16 Lock	679033104	WS1728	13
54	Lower Beam Jaw Mnt. Screw Flat Washer 5/16 Flat	678033104	WS1703	13
55	Flat Head Rivet	600000267		4
56	Lower Beam Bracket RH Complete	756200359	412-29	1
57	Lower Beam Bracket LH Complete	756200360	412-30	1
60	Lower Beam Bracket Mounting Screw	756650250	416-88	2
61	Lower Beam Bracket Mounting Screw 5/8-11 x 2 1/2 Hex Head	601012373	WS96	2
62	Lower Beam Bracket Mnt. Screw Lock Washer 5/8 Lock	679033109	WS1733	2
63	Lower Beam Bracket Mnt. Screw Nut 5/8-11 Hex Full	643023009	WS1358	2
64	Lower Beam Bracket Mnt. Screw 5/8-11 x 4 1/2 Hex Head	601012381	WS103	2
65	Lower Beam Bracket Lock Washer, 5/8 Lock	679033109	WS1733	2
66	Lower Beam Locating Pins	756160323	412-31	8
67	Lower Beam Bracket Gibs	756400363	412-32	2
69	Apron Stop Rod Bracket	756200365		1
70	Lower Beam Bracket Gib Screws 3/8-16 x 1" SSCP	621012634		10
71	Socket Head Cap Screw, 1/2-13 x 1 1/4"	611012273		2
72	Apron Gauge Bar	756130264	416-43	1
73	Apron Gauge Bar Stop Collar	756260265	416-54	1
74	Apron Gauge Bar Stop Collar Set Screw 3/8-16 x 3/4 Square Head	633012173	WS628	1
75	Apron Stop Swivel Pin	756160258	416-40	1
76	Apron Stop Swivel Pin Cotter Key 3/32 x 1 1/4	600073517	WS1528	1

NO. 612
APRON ASSEMBLY
PARTS IDENTIFICATION CHART

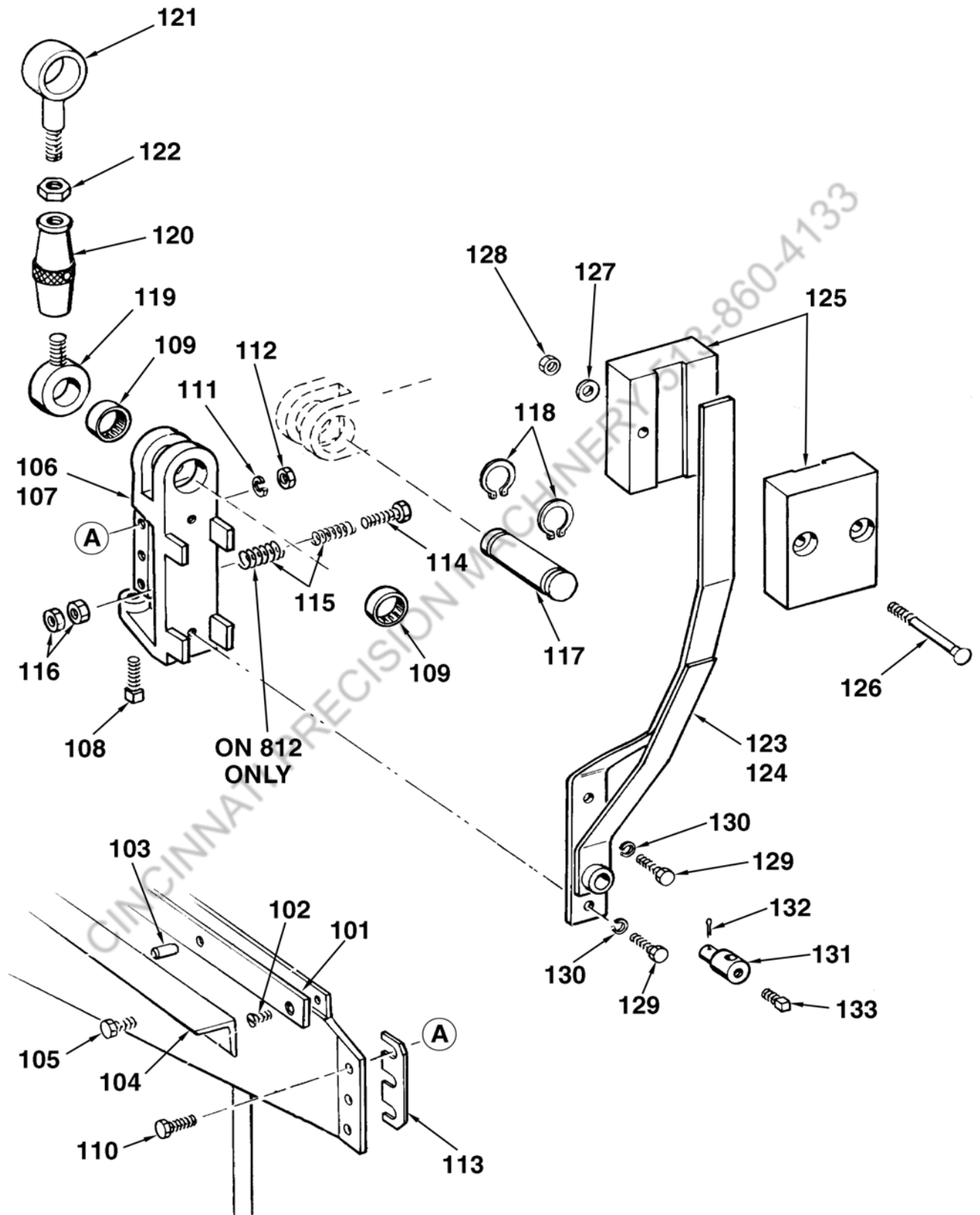

NO. 612
APRON ASSEMBLY
PARTS IDENTIFICATION LIST

ITEM NO.	PART NAME	PART NO.	OLD PART NO. (Ref. only)	QTY.
100A	Apron Complete (consists of items 100-105)	756020381	612-3M	1
100	Apron (Available only as assembly 756020381 above)			1
101	Apron Jaw	756020383	616-6R	1
102	Apron Jaw Screws 5/16-18 x 5/8 Socket Flat Head	613012130		13
103	Apron Jaw Dowel Pins, 1/4 Dia. x 1/2	600053314	WS1682	5
104	Apron Work Support	756180384	616-11	1
105	Apron Work Support Screw	601012361	WS145	5
106A	Apron Hinge RH Complete (consists of items 106, 108 & 109)	256990004	412-35	1
106	Apron Hinge RH (Available only as assembly 256990004 above)			1
108	Apron Adjusting Screws 1/2-13 x 1 3/4 Sq. Head	633012277	WS657	1
109	Apron Hinge Bearings	656235000	416-97	2
107A	Apron Hinge LH Complete (consists of items 107, 108 & 109)	256990005	412-36	1
107	Apron Hinge LH (Available only as assembly 256990005 above)			1
108	Apron Adjusting Screws 1/2-13 x 1 3/4 Sq. Head	633012277	WS657	1
109	Apron Hinge Bearings	656235000	416-97	2
110	Apron Hinge Mounting Bolts 5/8-11 x 2" Hex Head Cap	601012371	WS94	6
111	Apron Hinge Mounting Bolt Washers 5/8 Lock	679033109	WS1733	6
112	Apron Hinge Mounting Bolt Nuts 5/8-11 Hex Full	643023009	WS1358	6
113	Apron Hinge Shims	756720369	412-27	As Req.
114	Apron Bumper Spring Screw	601012183	WS37	2
115	Apron Bumper Spring	656184571	416-41	2
116	Apron Bumper Spring Screw Nuts 3/8-16 Hex Jam	649023005	WS1333	4
117	Apron Hinge Pin	756160242	416-31	2
118	Apron Hinge Pin Retaining Rings, 1 3/8	656164310	WS1974	4
119	Lower Eyebolt	756340267	416-25	2
120	Turnbuckle	756260268	416-26	2
121	Upper Eyebolt	756340269	416-78	2
122	Turnbuckle Lock Nut, 1/8 Hx Jam	649023012	WS1340	2

**NO. 612
APRON ASSEMBLY
PARTS IDENTIFICATION LIST**

ITEM NO.	PART NAME	PART NO.	OLD PART NO. (Ref. only)	QTY.
123	Counterweight Arm RH	756030376	412-24	1
124	Counterweight Arm LH	756030375	412-41	1
125	Counterweights	590061622	616-22	4
126	Counterweight Bolts 1/2-13 x 3 Carriage	639012283	WS2103	4
127	Counterweight Washers 1/2 Flat	678033107	WS1706	4
128	Counterweight Nuts 1/2-13 Square	659023008	WS1386	4
129	Counterweight Arm Mounting Screw 1/2-13 x 1 1/4 Hex Head	601012273	WS64	4
130	Counterweight Arm Mounting Screw Washer 1/2 Lock	679033107	WS1731	4
131	Apron Stop Swivel Pin	756160280	416-38	1
132	Apron Stop Swivel Pin Cotter Key 3/32 x 1 1/4	600073517	WS1528	1
133	Apron Stop Swivel Set Screw 3/8-16 x 5/8 Square Head	633012172	WS627	1

**NO. 612
HEAD AND LEG ASSEMBLY
PARTS IDENTIFICATION CHART**

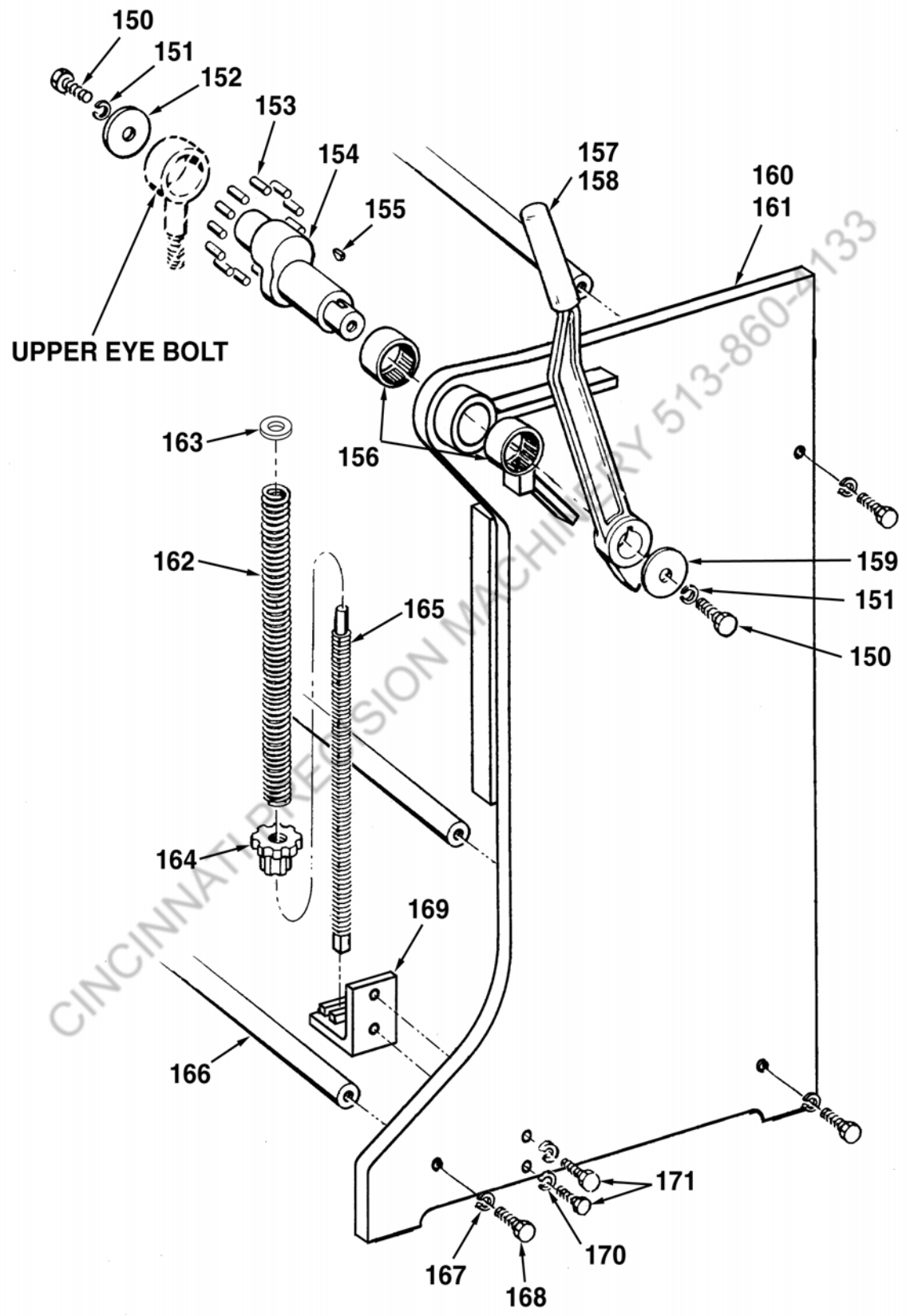

NO. 612
HEAD AND LEG ASSEMBLY
PARTS IDENTIFICATION LIST

ITEM NO.	PART NAME	PART NO.	OLD PART NO. (Ref. only)	QTY.
150	Washer Mounting Screw Hex Head Cap 3/8-16 x 3/4	601012173		4
151	Washer Mounting, 3/8 Lock	679033105	WS-1729	4
152	Upper Eye bolt Washer	756830271	416-80	2
153	Roller Bearings Torrington C4350	600255207	416-39	50
154	Brake Crank	756210270	416-77	2
155	Crank & Clamping Lever Key	600123927		2
156	Brake Crank Bearings Torrington BH 2824	656235014	416-98	4
157	Clamping Lever R. H.	756030273	416-16	1
158	Clamping Lever L. H.	756030274	416-17	1
159	Handle Washer	678033117		2
160	End Frame R. H.	756140351	814-100	1
161	End Frame L. H.	756140352	814-101	1
162	Lower Beam Lift Springs	656184574	616-12	2
163	Washer, Lift Spring 3/4"	678033110		2
164	Lower Beam Lift Spring Rod Adj nuts	756560257	416-36	2
165	Lower Beam Lift Spring Rods	756030367	814-135	2
166	Tie Rod	756030385	612-107	3
167	Tie Rod Mounting Screw Lock Washer, 1/2"	679033107	WS-1731	6
168	Tie Rod Mounting Hex Head Screw 1/2-13 x 1 1/2	601012275		6
169	Bracket, Lift Spring	756200366	814-104	2
170	Lock Washer, 1/2"	679033107	WS-1731	4
171	Hex Head Cap Screw, 1/2-13 x 1 1/2	601012275		4