

No. MBB 4181 & 4182

MAGNABEND

Electromagnetic Bending Brake



ROPER WHITNEY CORP



IN GOD WE TRUST

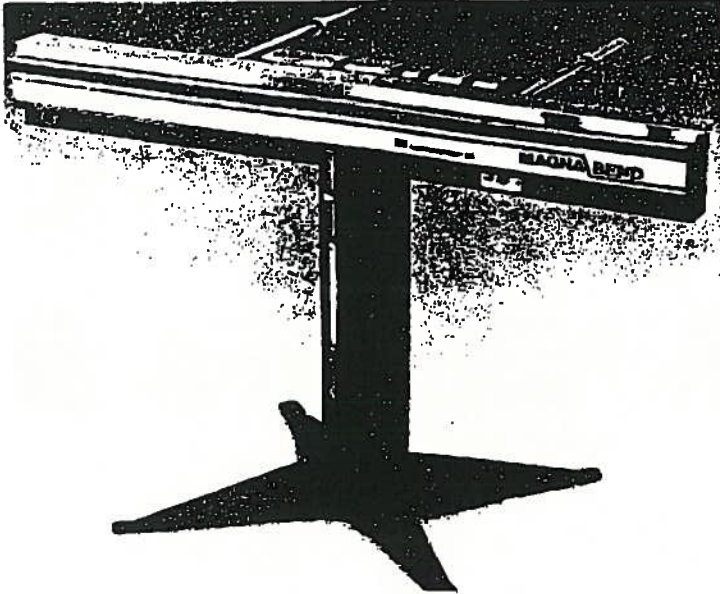

The MB4181 is a bending brake that employs an electromagnetic system for clamping sheet metal for the bending process. It comes complete with one full length and ten shorter keepers of varying lengths to accommodate a full range of width requirements.

SPECIFICATIONS

Capacity	18 ga. mild steel
Bending Width	49 inches
Weight	275 pounds
Electrical	115V, 1 ϕ , 60 HZ (MBB4181) 230V, 1 ϕ , 60 HZ (MBB4182)

WARNING

Mechanical Danger - Keep hands and fingers clear of clamping keepers at all times. Misuse or improper handling of the bending brake may result in accidental pinching that could cause injury to or loss of fingers.

Electrical Danger - Misuse or improper installation of bending brake connected to a source of electricity may result in accidental shock that could cause injury or death. Power cord installation must be grounded.

SET-UP INSTRUCTIONS

(See Figure 7)

1. Attach four legs (Items 19 & 20) to column (Item 18), using eight 3/8-16 x 3/4 socket head cap screws (Item 21). With approximately 5/16" clearance between the brake and the stiffening plate, guide the two screws down into the slots. Level the brake sub-assembly and tighten screws.
2. Set brake sub-assembly (Item 1) into slots in top of column, using two 3/8-16 x 3/4 socket head cap screws (Item 21) and stiffening plate (Item 22).
3. Place angle indicator rod (Item 12) and collar (Item 27) over handle (Item 8) and attach handle to underside of bending beam, using two 5/16-18 x 5/8 socket head cap screws (Item 10).



ROPER WHITNEY CORP.

2833 Huffman Blvd., Rockford, IL 61101
815/962-3011 TELEX: 25-7485

Division of Roper Industries, Inc.

SET-UP INSTRUCTIONS (Continued)

4. Attach anchor block (Item 13, attached to angle indicator rod) to magnetic base with two #10-24 x 3/4 socket head cap screws (Item 14). Be sure that brass actuator is assembled **above** microswitch lever in magnetic base.
5. Attach trays (Items 23 & 24) to rear of column with two 1/4-20 x 1/2 socket head cap screws (Item 25). Narrow tray is positioned to front, over top of column.
6. Attach gauge bars (Item 26) to rear of magnetic base, and add collars and thumbscrews (Items 27 & 28).
7. Fasten legs securely to floor with appropriate screws, or use optional foot plate assembly.
8. For Model MBB4181, connect power cord to 115 volt grounded outlet. For Model MBB4182, bring 230V, 1 phase, 60 HZ line to quick disconnect box mounted on rear of brake column.
9. When required to move the assembled bending brake (275 lb. weight), proper lifting shall be with an overhead or portable crane, and using a lifting sling placed securely about the magnet bending table and stand.

Do not attempt to slide the bending brake across the floor, because tipping may result in accidental damage to the brake, or cause personal injury.

OPERATING INSTRUCTIONS

Straight Bending

1. Be sure main power is turned on, and the ball detents on the underside of the full length keeper are properly located in the angled grooves in the magnetic base.
2. Insert the workpiece under the keeper. Tilt the keeper forward and align your bend with its front edge.
3. Depress and hold the safety button to apply a light clamping force.
4. Begin bending by lifting the handle. Full clamping will occur and the safety button can now be released. Continue bending until the desired angle is reached. The angle gauge on the handle indicates the angle between the bending beam and the magnetic base. The adjustable collar provides a stop for repeat operations.
5. Lower the handle to switch off the magnet and remove the workpiece.

OPERATING INSTRUCTIONS (Continued)

Lip or Hem

1. Proceed as with Straight Bending, but continue bend as far as bending beam will go (approximately 120°).
2. Reposition the keeper and workpiece as shown in Figure 1. Press the safety button and swing the beam over to partially flatten the lip.
3. Fully flatten lip by using magnetic clamping only. Position workpiece as shown in Figure 2. Press safety button and lift handle slightly.
4. Lower handle and remove workpiece.



Figure 1



Figure 2

Box Bending

1. Starting with a notched blank, make the first two bends using the full length keeper as in straight bending.
2. Select one or more of the shorter keepers and position them as shown in Figure 3. It is not necessary to make an exact length since the bend will carry over up to 1 inch between keepers, depending on the type and thickness of material being bent.

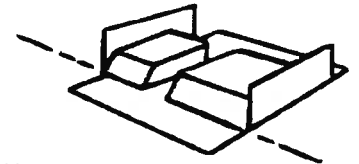

Figure 3

Partial Bends

1. The open end design of the MAGNABEND allows partial bending.
2. Position the portion of the workpiece to be bent under a keeper at the end of the magnetic base. Allow portion to be left flat to extend beyond the end. (Figure 4)
3. Proceed as with straight bending.

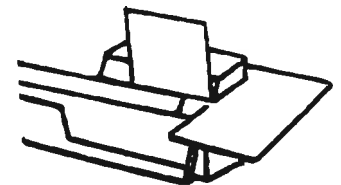

Figure 4

OPERATING INSTRUCTIONS (Continued)

Rolled Edges

1. Rolled edges of various diameters may be formed, using any mild steel round bar.
2. Position the workpiece, keeper and bar as shown in Figure 5. Be sure that keeper does not overlap front pole piece. Position the leading edge of the workpiece as nearly under the center of the bar as possible, to obtain a minimum flat section in the finished roll.
3. Wrap the workpiece around the bar with the bending beam as in straight bending. Reposition the workpiece as shown in Figure 6 and continue to wrap until the desired roll is reached. The number of wrapping operations will vary with the diameter of the bar and the material being bent.



Figure 5

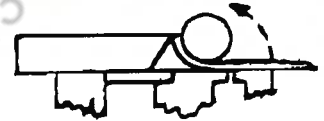
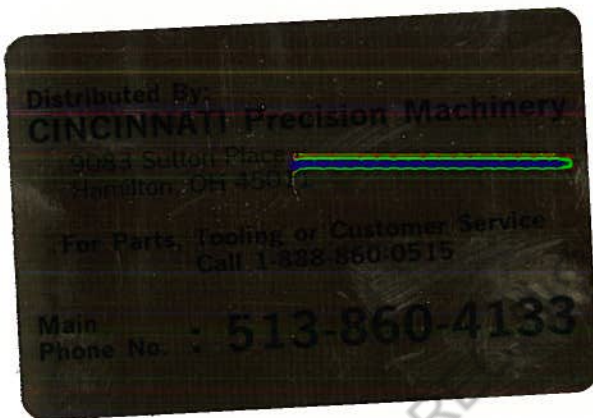

Figure 6



MBB-4181 SAFETY RULES

1. **WARNING:** Electrical danger—misuse or improper installation of bending brake connected to a source of electricity may result in accidental shock that could cause injury or death. Power cord installation must be grounded.
2. **WARNING:** Mechanical danger—keep hands and fingers clear of clamping keepers at all times. Misuse or improper handling of the bending brake may result in accidental pinching that could cause injury to or loss of fingers.
3. Do not operate bending brake without reading Operator's Manual and without proper supervisory instructions.
4. Bending brake is a one person machine and must be operated by qualified authorized personnel.
5. The magnetic bending base is intended only for bending sheet metal through the keeper clamps. Any other use may seriously damage the magnetic surfaces, or cause personal injury.

SAFETY RULES
(Continued)

6. For heavy duty bending, the mounting legs should be attached to the floor with 1/2" x 1 1/4" screws. If the bending brake is to be portable, the optional foot platform kit #258080004 should be used for additional stability.
7. Do not place any foreign objects between clamping keeper and magnetic work base.
8. When using short clamping keepers, do not store full-length clamping keeper on any structural part of the bending brake. This also applies to any foreign objects.
9. Do not clutter keeper tray with tools, bent parts, or scrap sheet metal. Only store keepers in the tray.
10. Do not place or hold any foreign steel bars or plates within the keeper area or attempt to reposition any keeper while the magnet is switched on. Failure to comply may seriously damage the magnetic surfaces or cause personal injury.
11. Proper handling procedures are required for large sheet metal lengths, as they may become awkward to handle when the magnet is switched off (upon lowering the bending beam).
12. Do not use bending brake if servicing is required.
13. When not in use, turn off electrical power.

REMEMBER!

The shapes to be bent on MAGNABEND are really only limited by the imagination. As you become more familiar with its operation, you will discover many possibilities beyond the capability of any conventional bending brake.

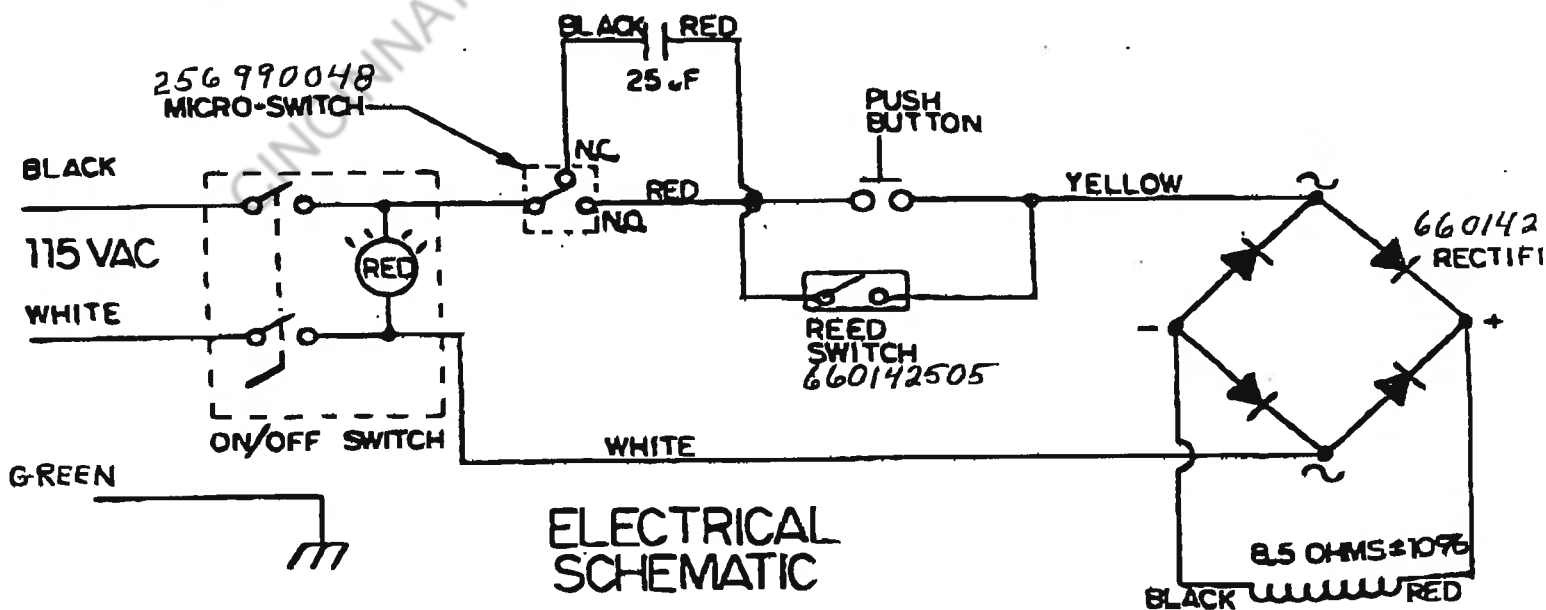

MAGNABEND PARTS LIST

<u>ITEM</u>	<u>QTY.</u>	<u>PART NO.</u>	<u>DESCRIPTION</u>
1	1	256130003	Brake Sub-Ass'y, Magnetic
2	3	256080001	Hinge Ass'y
3	3	756130447	Block, Hinge
4	3	756160470	Pin, Hinge
5	3	756260471	Wire, Retainer
6	1	756020442	Beam, Bending
7	1	756020443	Extension, Beam
8	1	756460445	Handle
9	1	656356308	Grip, Vinyl
10	2	611012130	Screw, Soc. Hd. 5/16-18 x 5/8
11	1	656000187	Scale, Angle
12	1	756030448	Rod, Angle Indicator
13	1	756130449	Block, Anchor
14	2	611012054	Screw, Soc. Hd. #10-24 x 3/4
15	1	756030450	Actuator, Microswitch
16	1	656346146	Nameplate
17	1	656346147	Nameplate, Warning
18	1	756060451	Column
19	2	756140452	Leg, R.H.
20	2	756140453	Leg, L.H.
21	10	611012173	Screw, Soc. Hd. 3/8-16 x 3/4
22	1	756060454	Plate, Stiffening
23	1	756440455	Tray, Front
24	1	756440456	Tray, Rear
25	1	611012086	Screw, Soc. Hd. 1/4-20 x 1/2
26	2	756030444	Bar, Gauge
27	3	756260446	Collar
28	3	641012628	Screw, Thumb
29	1	256130002	Cover Ass'y, Electrical
30	1	660082034	Switch, Safety
31	(2 pcs)	660152661	Switch, Isolator
		660152662	
32	1	256990048	Switch, Micro
33	1	256080005	Keeper, Full Length
34	1	756360432	Keeper, Half
35	1	756360433	Keeper, 4-3/4"
36	1	756360434	Keeper, 3-3/4"
37	1	756360435	Keeper, 2-3/4"
38	1	756360436	Keeper, 1-7/8"
39	1	756360437	Keeper, 1-3/8"
40	1	756360438	Keeper, 1"
41	1	756360439	Keeper, 3/4"
42	1	756360440	Keeper, 6"
43	1	756360441	Keeper, 12"

-7-

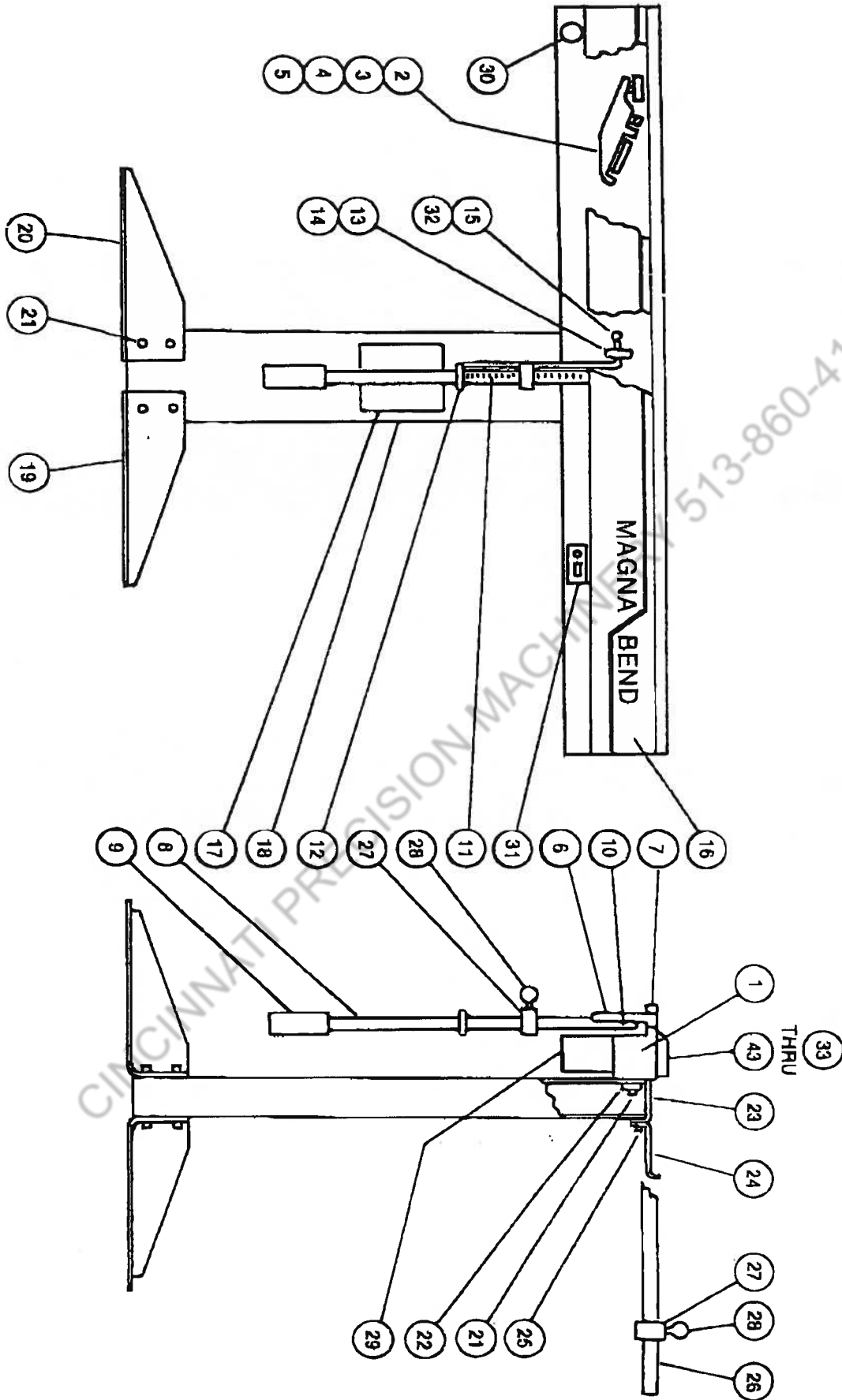

Figure 7