

# ROPER WHITNEY.

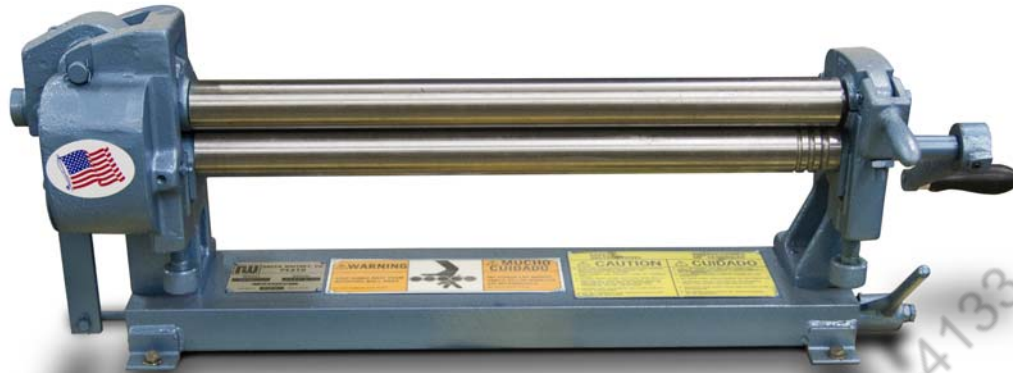

**MODELS NO. 0381, 381, 382, 383  
SLIP ROLL FORMER**

**OPERATION, PARTS & MAINTENANCE MANUAL**

<b>Model:</b>	<b>Purchased From:</b>
<b>Serial #:</b>	<b>Date Received:</b>

**USA  MADE**

*An American Tradition Since 1910*

Roper Whitney / 2833 Huffman Blvd. / Rockford, IL 61103 / 815-962-3011 / Fax 815-962-2227  
[www.roperwhitney.com](http://www.roperwhitney.com)

## FOREWORD

This manual has been prepared for the owner and operators of Roper Whitney Slip Roll Former. Its purpose, aside from operations instructions, is to promote safety through the use of accepted operating procedures. Read all instructions thoroughly before operating the machine.

Also contained in this manual is the parts list for your machine. It is recommended that only Roper Whitney or factory authorized parts be used as replacements.



Warranty Statement:

### **3 YEAR LIMITED WARRANTY**

Roper Whitney ("Manufacturer") warrants, commencing with the date of shipment to first end-user ("Customer") and for a period of thirty-six (36) months thereafter, all machinery and parts manufactured by Manufacturer to be free of defects in workmanship and material. **This warranty remains in force for the above time period only if all of Manufacturer's operational procedures are followed and recommended maintenance is performed.** If, within such warranty period, any machinery or parts manufactured by Manufacturer shall be proved to Manufacturer's satisfaction to be defective, such machinery or parts shall be repaired or replaced, at Manufacturer's option. All warranty claims are made F.O.B Manufacturer's plant, providing such machinery or parts are returned freight prepaid to Manufacturer's plant or designated service center for Manufacturer's inspection. All failed parts or components must be returned to Manufacturer prepaid for inspection before credit will be issued for new parts or components. Manufacturer's obligation hereunder shall be confined to such repair or replacement and does not include any charges, direct or indirect, for removing or replacing defective machinery or parts. No warranty shall apply to machinery, or parts or accessories, which have been furnished, repaired, or altered by others so as, in Manufacturer's judgment, to affect the same adversely or which shall have been subject to negligence, accident or improper care, installation, maintenance, storage, or other than normal use or service, during or after shipment. No warranty shall apply to the cost of repairs made or attempted outside of Manufacturer's plant or designated service center without Manufacturer's authorization. No warranty shall apply with respect to machinery or part not manufactured by Manufacturer, including but not limited to motors, accessories, electrical and hydraulic components, if such machinery or part is subject to warranty by the manufacturer of such machinery or part. No warranty claims by Customer will be honored with respect to any machinery or part from which the name and date plate has been removed or is otherwise no longer located or exhibited on such machinery or part. **THE FOREGOING WARRANTIES ARE IN LIEU OF ALL OTHER WARRANTIES EXPRESSED OR IMPLIED, INCLUDING, BUT NOT LIMITED TO, ANY IMPLIED WARRANTY OF MERCHANTABILITY AND IMPLIED WARRANTY OF FITNESS FOR A PARTICULAR PURPOSE. MANUFACTURER SHALL NOT BE SUBJECT TO ANY OTHER OBLIGATIONS OR LIABILITIES WHATSOEVER WITH RESPECT TO MACHINERY, PARTS, ACCESSORIES, OR SERVICES MANUFACTURED OR FURNISHED BY IT OR ANY UNDERTAKINGS, ACTS, OR OMISSIONS RELATING THERETO. UNDER NO CIRCUMSTANCES SHALL MANUFACTURER BE LIABLE FOR ANY CONSEQUENTIAL OR OTHER DAMAGES, EXPENSES, LOSSES, OR DELAYS HOW SO EVER CAUSED.**

**THERE ARE NO WARRANTIES THAT EXTEND BEYOND THE DESCRIPTION ON THE FACE HEREOF.**

**Note: Consumable tooling is not covered under the 3 year manufacturer's warranty.**

RETURN OF THE PRODUCT REGISTRATION CARD FURNISHED WITH THE PRODUCT IS NECESSARY TO OBTAIN WARRANTY COVERAGE THEREON. CARD MUST BE FULLY COMPLETED, SIGNED BY THE PURCHASER, AND IF APPLICABLE, SIGNED BY THE DISTRIBUTOR. RETURN REGISTRATION CARD TO:

Roper Whitney 2833 Huffman Blvd. Rockford, IL 61103  
815-962-3011 / Fax 815-962-2227  
www.roperswhitney.com

## SAFETY LABELS

**Do not operate the machine without the proper safety labels in place.** If your machine is missing the following labels, please contact Roper Whitney Co. or your authorized Roper Whitney distributor to order.



## **SAFETY INSTRUCTIONS**

1. Be sure that the machine is securely bolted onto the pedestal or to the customer supplied bench. Pedestal or work bench should be bolted to the floor.
2. Machine to be operated by authorized personnel who have been trained by their supervisor with the working and safety features of the machine, and by reading and understanding the operator's manual.
3. Do not misuse the slip rolls by using them for other than their intended use.
4. Always keep hands clear of entry area to rolls while operating.
5. Do not remove, paint over, alter, or deface any machine-mounted warning and instruction plates and signs.
6. Do not use machine if servicing is required.
7. Use safety glasses and required protective tools. Wear protective foot wear or safety shoes. Jewelry such as rings and watches should be removed when operating the machine.
8. Be alert to all potential hazards. Notify your supervisor whenever you feel there is a hazard involving the equipment or the performance of your job.

## **INSTALLATION**

### **Receiving**

Immediately upon receiving the machine, check it very carefully for damage or loss of parts in transit. Since all equipment is sold F.O.B., the Roper Whitney plant, our responsibility for transit damage ceases when the transportation company signs the bill of lading indicating that it has received all of the items listed on the bill of lading in good condition. Report any loss or damage to the delivering carrier promptly to insure proper handling of your claim.

### **Leveling**

Be sure machine is solid and reasonably level on all four points so there is no camber or twist to the machine. If machine is shipped on a pallet, be sure to remove from pallet and place directly on flooring. Machine must be securely bolted to bench. Bolt holes are provided in base of machine.

### **Cleaning**

In spite of precautions taken in preparing the machine for shipment, dirt and foreign material may accumulate on machine and other parts during transit, and can cause considerable damage unless thoroughly cleaned. It is extremely important to inspect and thoroughly clean off any dirt and foreign material that may have accumulated. DO NOT attempt to blow dirt out with an air hose as this may force some foreign material into undesirable areas. Remove rust proofing compound with an acceptable solvent.

# SLIP ROLL FORMERS 0381, 381, 382, 383



**No. 381**

These machines are available in four different sizes. All four models offer the standard front roll drive. These units may be mounted directly to a sturdy work bench or to an optional fabricated pedestal, designed specifically for each unit.

MODEL	0381	381	382	383
Capacity.....ga.	24	22	22	20
Max Length.....ins.	42	36	30	24
Min Diameter.....ins.	3	3	3	3
Shipping Weight Boxed..lbs.	270	250	225	190

## INSTRUCTIONS

**CAUTION:** Be sure that the machine is securely bolted onto pedestal or to customer supplied bench. Pedestal or work bench should be bolted to floor.

1. Adjust Lower Roll (24) to grip the metal firmly and evenly but without straining the machine. Lower Roll (24) is adjusted up or down with the two lower Adjusting Screws (7).

2. Adjust Rear Roll (25) to form the metal up as it travels through the rollers. Rear Roll (25) is adjusted up or down with the two rear Adjusting Screws (7). Be sure Rear Roll (25) is parallel with Lower Roll (24). If rolls are not parallel, the formed metal will be conical in shape instead of cylindrical.

3. Feed the stock to the rolls only from the front.

4. As the front rolls grip the stock, lift the rear end of the metal upward. This will help reduce the flat spot on the leading edge of the sheet and will also cause the leading edge to pass over the rear roll readily.

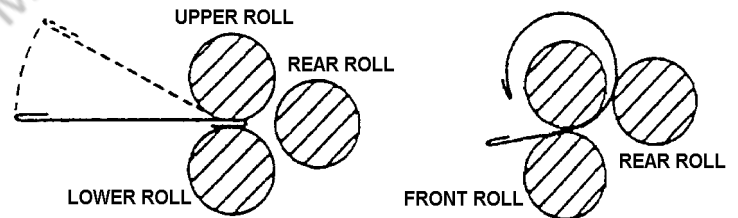

5. The diameter of the formed cylinder is determined by the position of the Rear Roll (25). To increase the diameter of a cylinder, lower Rear Roll (25) by turning the two rear Adjusting Screws (7) counter clockwise. To reduce the diameter of a formed cylinder, raise Rear Roll (25) by turning the two rear adjusting Screws (7) clockwise. The two rear Adjusting Screws (7) should be turned an equal number of turns in order to keep the Rear Roll (25) parallel with the front gripping rolls.

6. To remove a cylindrical piece without distorting it, lift up Locking Handle, raise Right Hand Housing Cap and turn Cam Handle (6) down. This raises the outboard end of the Upper Roll (23) and allows the formed cylinder to be slipped off of the Upper Roll (23).

7. The Lower Roll (24) and the Rear Roll (25) have grooves of varying widths in one end. These are for the purpose of accommodating a wired edge when forming a shape or when forming wire into a ring.

8. "X" points should be lubricated daily with a good grade machine oil. "Y" points should be greased weekly with Alemite #33 or equal.

# PEXTO FORMING MACHINES

Forming Machines, or Slip Roll formers, are intended for rolling sheet metal or forming cylinders of various diameters.

The two pinch rolls feed the sheet against the rear roll, curving the sheet and forming the cylinder. The rear or forming roll can be adjusted by screws on the rear of left and right end housings, varying the diameter of the required cylinder. Pinch rolls can be adjusted for stock thickness by screws on the front end of the housings.

The capacity ratings of **PEXTO** forming machines are based on forming mild steel, fully annealed, the full length of the rolls and are considered as standard by the sheet metal trade for forming rolls of a specified diameter and length. Definite capacities, however, depend upon the diameter and length of the cylinder to be formed and the number of passes through the rolls to obtain a given diameter. Stiffness of material and uniformity desired are also factors. When a forming machine is overloaded, the immediate result will be deflection in the center of the rolls, resulting in cylinders bulged in the center.

Three inch diameter forming rolls have longitudinal grooves in the rear forming roll to assist in starting the sheet. Forming rolls 3" in diameter and larger have all three rolls driven as standard. Three roll drive for rolls under 3" in diameter at extra cost.

In order to reduce the number of rear roll adjustments when sheets are of light gauge, proceed as follows:

1. Insert the sheet between two pinch rolls.
2. Bend the sheet upwards and slightly around the top roll.
3. Continue to pass the sheet through the machine.

This will also reduce the flat spot on the leading edge of the sheet.

The right-hand housing is provided with a hinged journal cap and lifting latch. After the cylinder is formed, the latch is lifted and the lever is pressed down. This raises the top roll and the cylinder can be slipped off the roll without distortion.

Forming machines are provided with grooves in the right end of the lower and rear rolls to allow for forming cylinders with a wired edge.

**WARNING:** Before operating, machines **must** be bolted to the work bench. If the floor stand has been provided, machine must be bolted to the floor stand with bolts provided. Stand **must** be securely lagged to the floor.

# PARTS IDENTIFICATION CHART - SLIP ROLL FORMERS 0381, 381, 382, 383

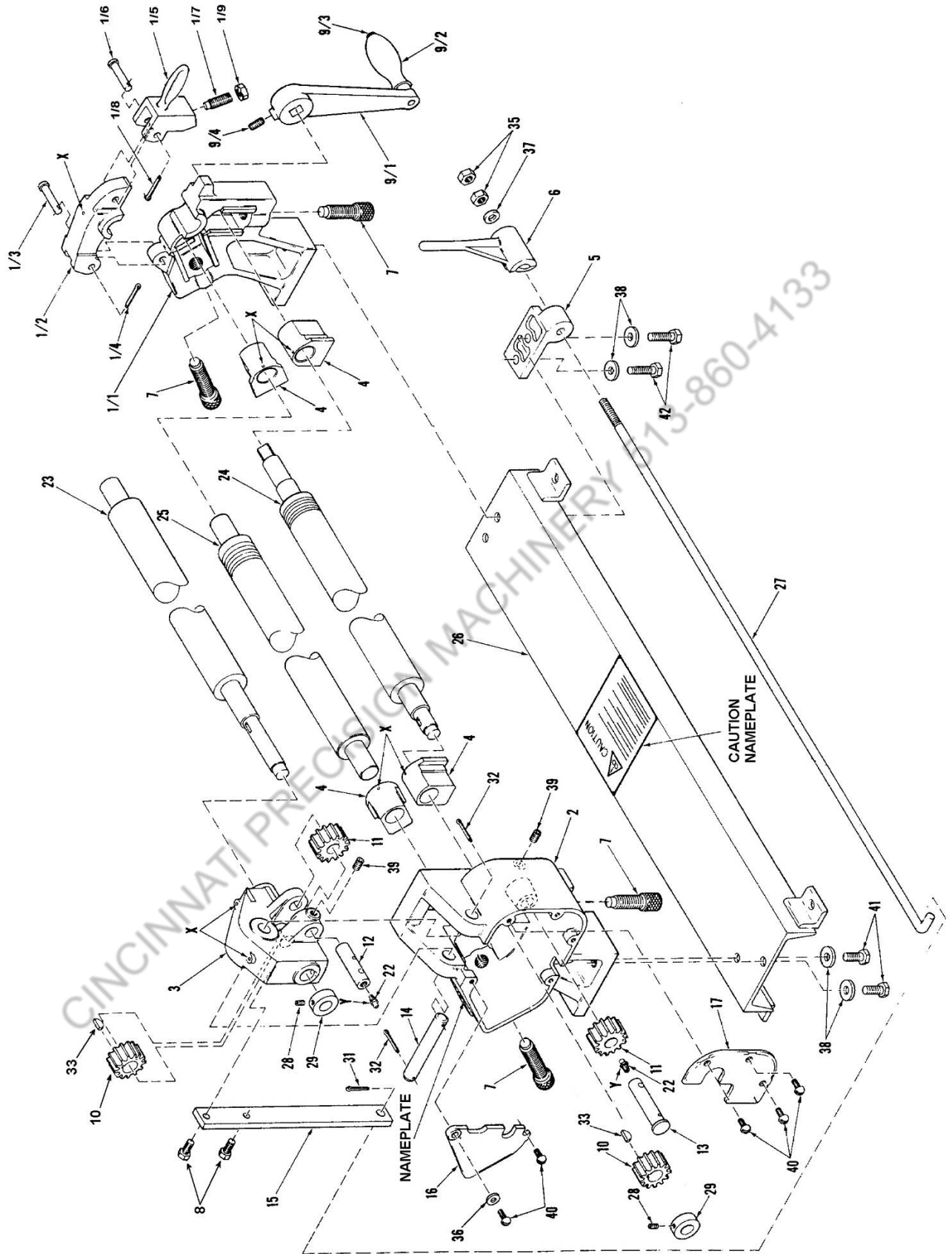

## PARTS LIST --- 0381, 381, 382, 383

INDEX	CATALOG NO.	PART NAME	NO. REQ'D
1/1	267990018	R.H. Housing/Locking Handle Assembly	1
1/2	*	R. H. Housing Cap	1
1/3	*	Pin	1
1/4	*	Cotter Pin 3/32 x 5/8	1
1/5	*	Locking Handle	1
1/6	*	Pin	1
1/7	*	Locking Handle Screw 1/2-13 x 1 1/2"	1
1/8	*	Cotter Pin 3/32 x 5/8"	1
1/9	*	Check Nut 1/2"	1
2	767490101	Left Hand Housing	1
3	767170102	Rocking Box	1
4	767170103	Box	4
5	767210104	Cam	1
6	767210105	Cam Handle	1
7	767650175	Adjusting Screw	4
8	601012173	HHC Screw 3/8-16 x 3/4	2
9	230700008	Hand Crank Assembly	1
9/1	767460096	Crank	1
9/2	767460209	Handle	1
9/3	767210097	Crank Stale	1
9/4	621012132	Socket Set Screw 5/16-18 x 7/8	1
10	767380108	Roll Gear (10851)	2
11	767380109	Compensating Gear (10852)	2
12	767680111	Upper Compensating Gear Stud	1
13	767680112	Lower Compensating Gear Stud	1
14	767160113	Rocking Box Pin	1
15	767030114	Lifting Lever	1
16	767220115	Front Cover Plate	1
17	767220116	Rear Cover Plate	1
22	600134001	1/8 straight Alemite Fitting	2
23	767630080	Upper Roll - 0381	1
23	767630079	Upper Roll - 381	1
23	767630081	Upper Roll - 382	1
23	767630070	Upper Roll - 383	1
24	767630083	Lower Roll - 0381	1
24	767630082	Lower Roll - 381	1
24	767630084	Lower Roll - 382	1
24	767630071	Lower Roll - 383	1

\* Not Sold Separately - Part Of An Assembly



**PARTS LIST --- 0381, 381, 382, 383**

<b>INDEX</b>	<b>CATALOG NO.</b>	<b>PART NAME</b>	<b>NO. REQ'D</b>
25	767630086	Rear Roll - 0381	1
25	767630085	Rear Roll - 381	1
25	767630087	Rear Roll - 382	1
25	767630072	Rear Roll - 383	1
26	767060089	Machine Base Assembly - 0381	1
26	767060088	Machine Base Assembly - 381	1
26	767060090	Machine Base Assembly - 382	1
26	767060073	Machine Base Assembly - 383	1
27	767030092	Cam Rod - 0381	1
27	767030091	Cam Rod - 381	1
27	767030093	Cam Rod - 382	1
27	767030074	Cam Rod - 383	1
28	621012126	Socket Set Screw 5/16-18 x 3/8	2
29	767260110	Collar	2
31	600073514	Cotter Pin 3/32 x 3/4	1
32	600073527	Cotter Pin 1/8 x 1	2
33	600123909	#9 Woodruff Key	2
35	649023006	Check Nut 7/16-14	2
36	678033104	Washer 5/16	1
37	678033106	Washer 7/16	1
38	678033107	Standard Washer 1/2	4
39	621012170	Socket Set Screw 3/8-16 x 1/2	2
40	615012130	Button Head Screw 5/16-18 x 5/8	5
41	601012271	Hex Head Cap Screw 1/2-13 x 1	2
42	601012275	Hex Head Cap Screw 1/2-13 x 1 1/2	2

# THIRD ROLL DRIVE PARTS LIST --- 0381, 381, 382, 383

## OPTIONAL THIRD ROLL DRIVE

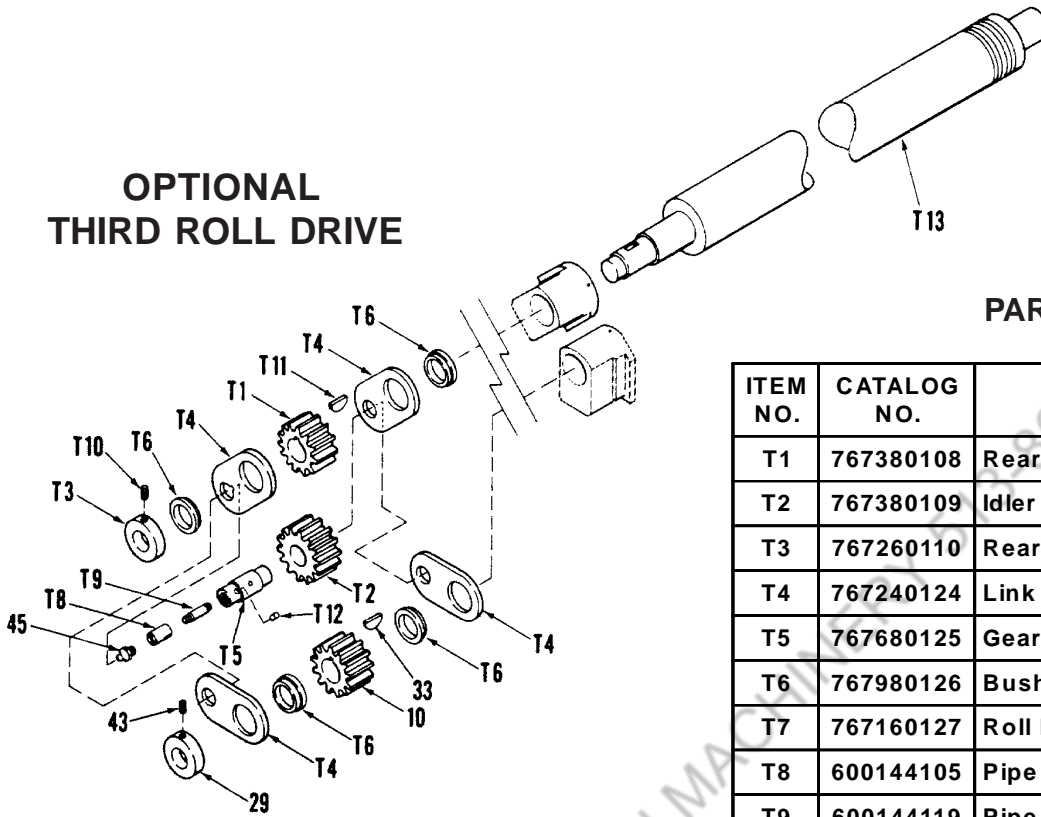

## PARTS LIST

ITEM NO.	CATALOG NO.	PART NAME	NO. REQ'D
T1	767380108	Rear Roll Gear	1
T2	767380109	Idler Gear	1
T3	767260110	Rear Roll Collar	1
T4	767240124	Link	4
T5	767680125	Gear Idler Shaft	1
T6	767980126	Bushing	4
T7	767160127	Roll Pin	1
T8	600144105	Pipe Coupling 1/8	1
T9	600144119	Pipe Nipple 1/8 x 1-1/2	1
T10	621012126	SS Screw 5/16-18 x 3/8	1
T11	600123909	#9 Woodruff Key	1
T12	767160128	Pin	1
T13	767630121	Rear Roll - 0381	1
T13	767630122	Rear Roll - 381	1
T13	767630123	Rear Roll - 382	1
T13	767630120	Rear Roll - 383	1
10	767380108	Roll Gear	1
29	767260110	Collar	1
33	600123909	#9 Woodruff Key	1
43	621012126	SS Screw 5/16-18 x 3/8	1
45	600134001	1/8 Alemite Fitting Straight	1

## LUBRICATION

All roll and gear bearing surfaces are equipped with standard grease fittings. Some of these grease fittings are only accessible by removing the top cover plate and the rear cover plate. These areas should be lubricated using a grease gun once each week. We recommend a good multipurpose grease. After every thirty days of operation, apply grease to the gears by removing the top cover plate and main housing end plate. Inspect all bolts and set screws on a regular basis to insure that they are secure.

We recommend that the rolls be lightly oiled when not in use to prevent rusting.

CINCINNATI PRECISION MACHINERY 513-860-4133