

NOS. 29, 58, 68 FOOT PRESSES

INSTRUCTIONS AND PARTS LIST

NOS. 58,68 - 5 TON PUNCHING POWER 2" HOLE THRU 16 GAUGE MILD STEEL



**NO. 58 AND 68
FOOT PRESSES**

SPECIFICATIONS	29	58	68
Capacity	5 tons	5 tons	5 tons
Depth of Throat	10"	18"	24"
Height of Throat	5 3/4"	5 3/4"	5 3/4"
Length of Stroke	1"	1"	1"
Adjustment of Ram	3/4"	3/4"	3/4"
Die Space with Stroke Down & Adjustment up	5"	5"	5"
Diameter of Punch Shank Hole in Ram	1"	1"	1"
Depth of Punch Shank Hole in Ram	1 1/4"	1 1/4"	1 1/4"
Slug Hole clearance	3" x 5"	3" x 5"	3" x 5"
Bed Plate Holes - Center to Center	6 3/4"	6 3/4"	6 3/4"
Floor Space Required	18" x 25"	18" x 34"	18" x 40"
Weight	375 lbs.	485 lbs	535 lbs

Standard equipment includes : One side gauge, one depth gauge, one F8 and F28 Punch Holder, one 20 and 40 Die Adaptor, one F 2 3/4 die shoe, one set 1/2" punch and die, one set stripper arms, and A7 stripper plate.



ROPER WHITNEY OF ROCKFORD, INC.

2833 HUFFMAN BLVD., ROCKFORD, ILLINOIS 61103-3990 * 815/962-3011 * FAX 815/962-2227
 Website: www.roperwhitney.com * Email: info@roperwhitney.com

INSTRUCTIONS

CARE: Oil ram gibs and toggle assembly daily.

OPERATION: To change punches, loosen punch retainer bolt nuts and punch retainer set screw. Remove punch holder.

To change dies, pivot die shoe forward. Remove die or die adaptor and replace with desired die or die adaptor. Return die shoe to proper position. Lower punch thru die. Align die so clearance is evenly distributed around punch. Tighten die shoe bolt nuts and recheck alignment.

TOGGLE CONNECTING LINKS: If toggles are not positioned correctly the press will punch hard or lock. Correct by loosening or tightening ram lever stop screw with foot treadle depressed.

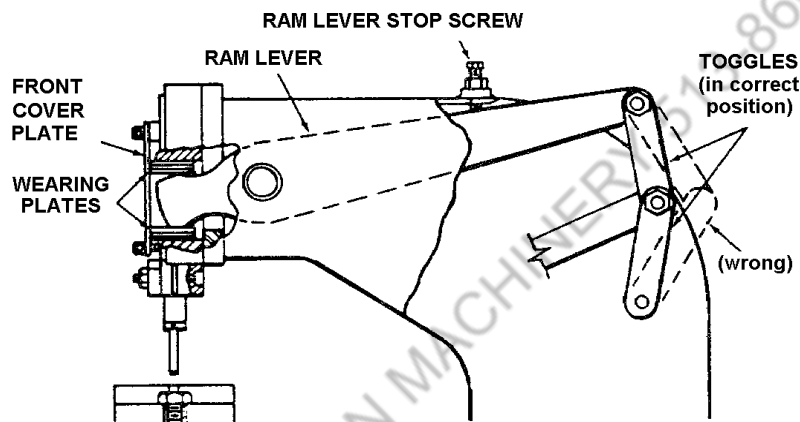

RAM ADJUSTMENT: Punch should enter die approximately 1/16". Toggle connecting links should be in the correct position as shown in the illustration. To correct adjustment:

1. Check to see that connecting link toggle position is correct.
2. Remove front cover plate and reposition wearing plates to achieve correct penetration.

RAM LOOSENESS: Loosen gib bolts on R.H. gib and remove one gib shim. If still loose, repeat on L.H. gib.

FOR MAXIMUM OPERATOR SAFETY DO:

1. Read and understand this manual.
2. Use only punches and dies marked with a **W** or **R-W** designed for this tool.
3. Be sure you punch within the five ton capacity of this tool. Type and thickness of material versus final hole size will give you this tonnage.
4. Wear safety glasses.

FOR MAXIMUM OPERATOR SAFETY DO NOT:

1. Use punches and dies that are chipped or dulled.
2. Punch over capacity of the tool.
3. Nibble. Punch a full hole not a half hole as punch may contact die.

NOS. 29, 58, 68 PARTS IDENTIFICATION CHART

RAM; WEARING PLATES

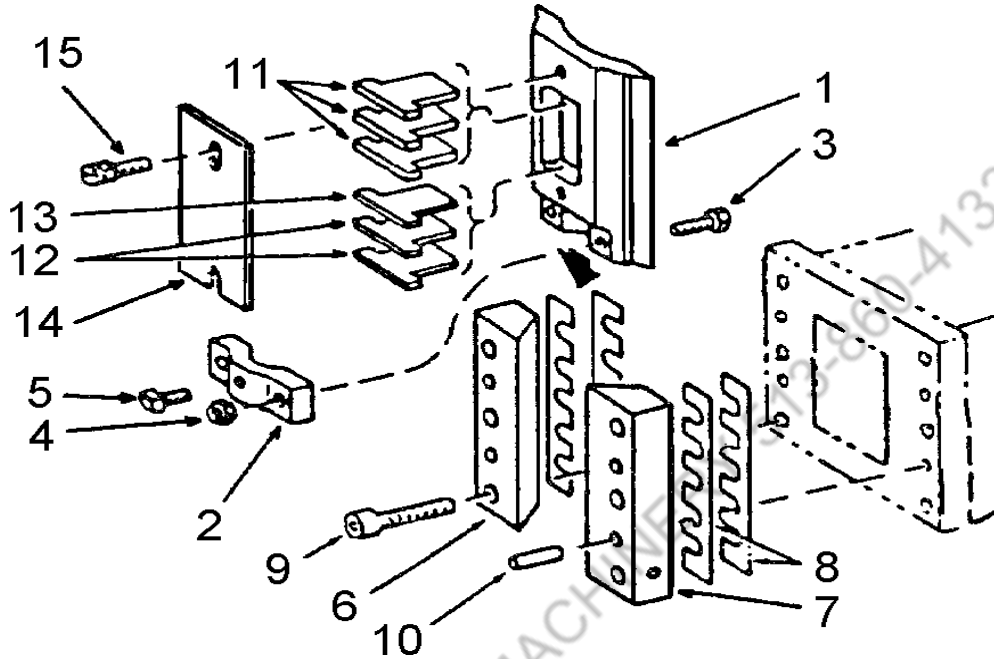

ITEM NO.	PART NO.	PART NAME	NO. REQ'D	OLD PART NO.
1	232940001	Ram w/Punch Retainer	1	29-2
2	731600134	Punch Retainer	1	29-5-R
3	731650275	Punch Retainer Screw	2	29-6
4	600023026	Punch Retainer Acorn Nut (5/16-18)	2	
5	633012131	Punch Retainer Screw (SHSCP 5/16-18 x 3/4)	1	WS 615
6	731400085	L.H. Gib	1	58-20
7	731400085	R.H. Gib	1	58-21
8	731720086	Gib Shim	4	58-22
9	611012181	Gib Bolt Screw (SHC 3/8-16 x 1 3/4)	6	WS 541
10	600043266	Gib Taper Pin (#6 x 2)	4	WS 1503
11	731060073	1/8" Wearing Plate	4	28-16
12	731060081	3/32" Wearing Plate	2	28-116
13	731060074	1/16" Wearing Plate	1	28-17
14	731060072	Front Cover Plate	1	28-15
15	611012090	Front Cover Plate Screw (SHC 1/4-20 x 7/8)	2	28-28

NOS. 29, 58, 68 PARTS IDENTIFICATION CHART

FRAME; BASE; CONNECTING LINKS

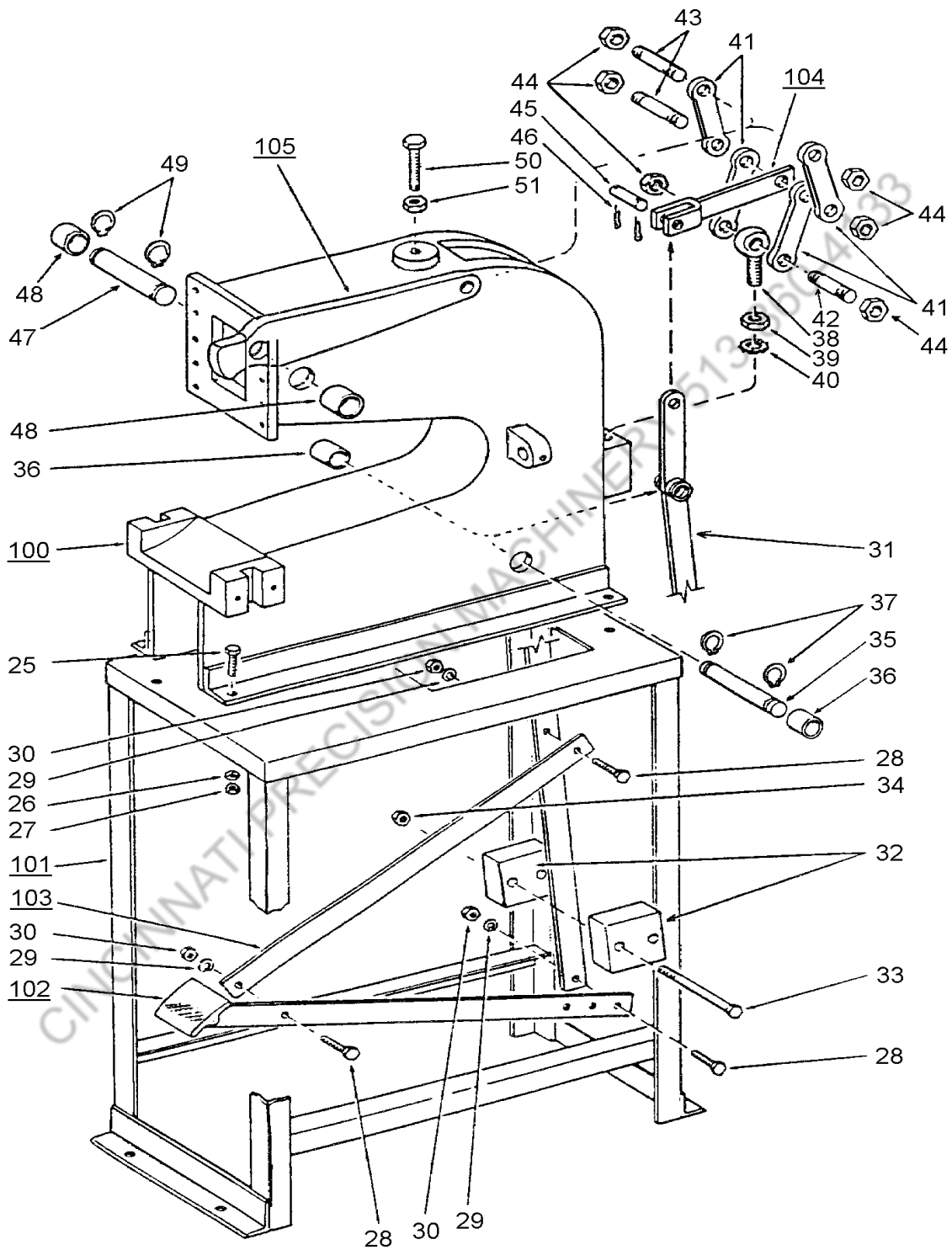

Item Nos. 100 thru 105 vary in size per each model of press
See parts list (pg. 5) for these items.

NOS. 29, 58, 68 PARTS IDENTIFICATION LIST

FRAME; BASE; CONNECTING LINKS

ITEM NO.	PART NO.	PART NAME	NO. REQ'D	OLD PART NO.
25	601012273	Stand Mounting Bolts (HHC 1/2-13 x 1 1/4	4	WS 64
26	679033107	Stand Mounting Bolt Washer (Lock 1/2)	4	WS 1731
27	643023007	Stand Mounting Bolt Nut (Hex Full 1/2-13)	4	WS 1356
28	601012277	Foot Treadle Tie Brace Bolt (1/2-13 x 1 3/4)	3	WS 66
29	679033107	Foot Treadle Tie Brace Bolt Washer (1/2)	3	WS 1731
30	643023007	Foot Treadle Tie Brace Bolt Nut (1/2-13)	3	WS 1356
31	731030083	Vertical Foot Treadle	1	58-6
32	590000583	Counterweight	2	58-3
33	639012387	Counterweight Bolt (Carriage 5/8-11 x 6)	2	WS 2129
34	643023009	Counterweight Bolt Nut (Full 5/8-11)	2	WS 1358
35	731160094	Vertical Foot Treadle Hinge Pin	1	58-9
36	600194614	Vertical Foot Treadle Hinge Pin Bushing	2	58-17
37	600164304	Vertical Foot Treadle Hinge Pin Lock Ring	2	WS 1970
38	731340071	Ram Adjusting Eyebolt	1	28-14
39	649023011	Ram Adjusting Eyebolt Nut (Hex 7/8-9)	1	WS 1339
40	683033111	Ram Adjusting Eyebolt Washer (Lock 7/8)	1	WS 1745
41	731240070	Connecting Link	4	28-13
42	731160076	Lower Connecting Link Bolt	1	28-22
43	731160075	Upper Connecting Link Bolt	2	28-21
44	730560055	Connecting Link Bolt Nut	6	8-12
45	731160084	Treadle Yoke Pin	1	58-10
46	600073517	Treadle Yoke Pin Cotter Key (3/32 x 1 1/4)	2	WS 1528
47	731160097	King Pin	1	58-4
48	600194613	King Pin Bushing	2	58-5
49	600164305	King Pin Lock Ring	2	WS 1972
50	633012375	Ram Lever Stop Screw (SHSCP 5/8-11 x 3)	1	WS 684
51	649023009	Ram Lever Stop Screw Nut (Hex 5/8-11)	1	WS 1337

Item No.	Part Name	No. Req.	No. 29		No. 58		No. 68	
			Part No.	Old Part No.	Part No.	Old Part No.	Part No.	Old Part No.
100	Frame	1	731140087	29-1M	731140095	58-1M	731140104	68-1M
101	Stand	1	731060089	29-1040	731060102	58-13	731060109	68-6
102	Foot Treadle	1	731670090	28-6	731670099	58-8	731670106	68-3
103	Vertical Foot Treadle Bar Tie Brace	1	731180091	28-6-3	731180098	58-7	731180107	68-4
104	Treadle Yoke	1	731840093	28-1011	731840103	58-200	731840103	58-200
105	Ram Lever	1	731030088	29-3	731030096	58-2	731030105	68-2

NOS. 29, 58, 68 PARTS IDENTIFICATION LIST

GAUGES

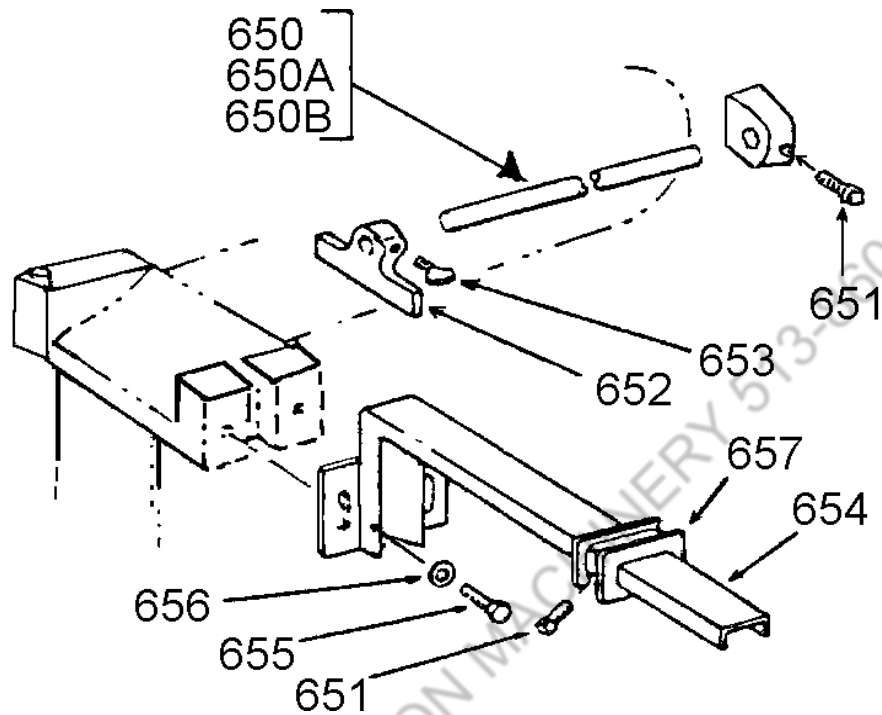

ITEM NO.	PART NO.	PART NAME	NO. REQ'D	OLD PART NO.
650	731030092	Depth Gauge Rod (No. 29 Press only)	1	28-31
650A	731030101	Depth Gauge Rod (No. 58 Press only)	1	58-12
650B	731030108	Depth Gauge Rod (No. 68 Press only)	1	68-5
651	633012172	Depth Gauge Rod & Side Gauge Casting Screw (SHSCP 3/8-16 x 5/8)	2	WS 627
652	731420078	Depth Gauge Casting	1	28-30
653	641012088	Depth Gauge Casting Thumb Screw (1/4-20 x 5/8)	1	WS 1955
654	731420079	Side Gauge	1	28-32
655	601012173	Side Gauge Mounting Screw (HHC 3/8-16 x 3/4)	2	WS 31
656	678033105	Side Gauge Mounting Screw Washer (Flat 3/8)	2	WS 1704
657	731730080	Side Gauge Casting	1	28-81

NOS. 29, 58, 68 PARTS IDENTIFICATION CHART

AUXILIARY ATTACHMENTS

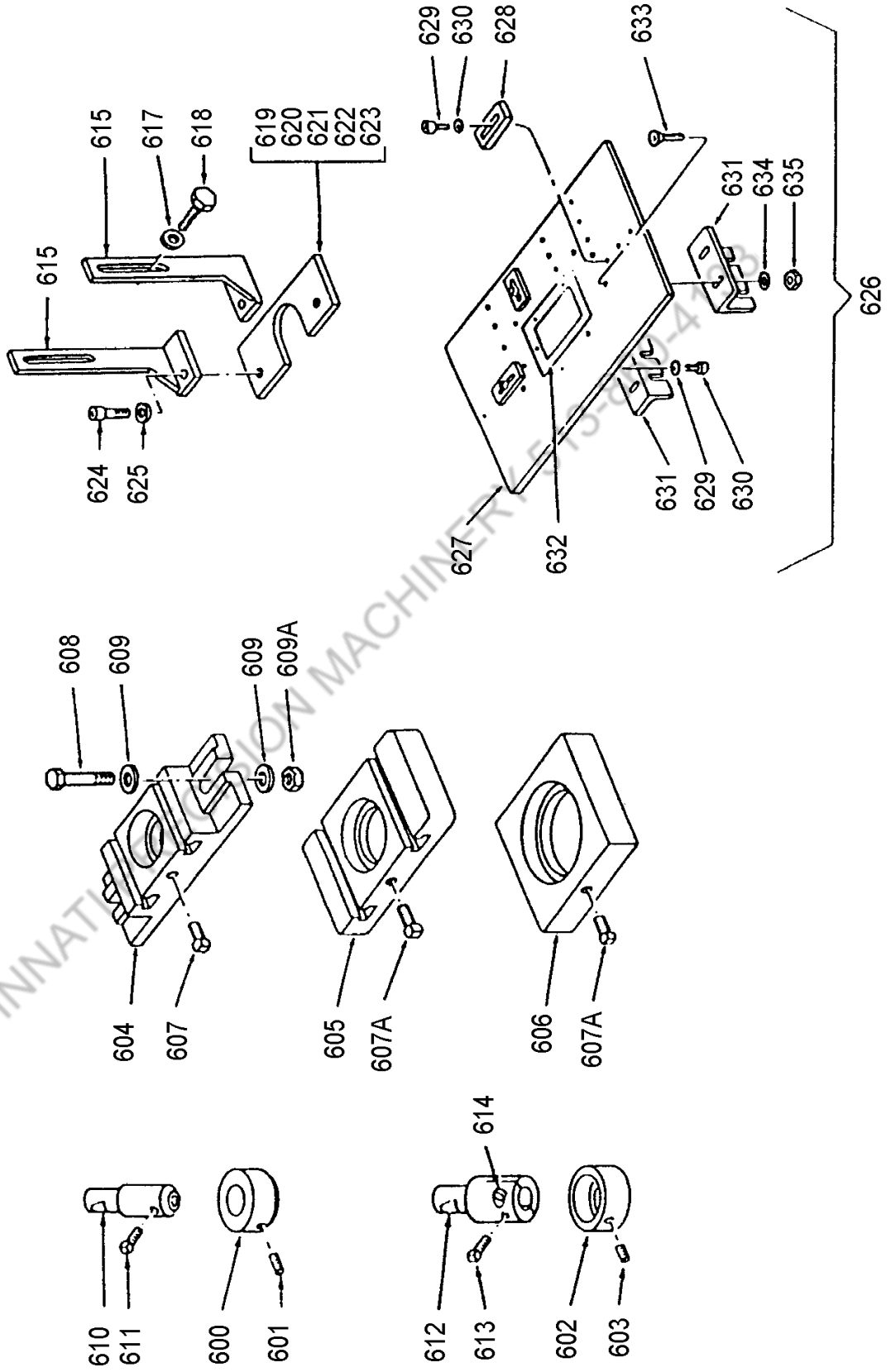

NOS. 29, 58, 68 PARTS IDENTIFICATION LIST

AUXILIARY ATTACHMENTS

ITEM NO.	PART NO.	PART NAME	NO. REQ.	OLD PART NO.
600	136313020	No. 20 Die Adaptor	1	28-127
601	600325907	Die Adaptor Set Screw (5/16-18 x 3/4)	1	WS 715
602	136323040	No. 40 Die Adaptor	1	28-126
603	600325904	Die Adaptor Set Screw (5/16-18 x 5/16)	1	WS 794
604	139404030	F 2 3/4 Die Shoe	1	28-3
605	139415050	F 3 3/4 Die Shoe	1	28-90
606	139426060	F 4 3/4 Die Shoe	1	28-95
607	621012173	Die Shoe Set Screw (SSCP 3/8-16 x 3/4)	1	WS 848
607A	633012179	Die Shoe Set Screw (SHSCP 3/8-16 x 1 1/2)	1	WS 632
608	601012377	Die Shoe Bolt (HHC 5/8-11 x 3 1/2)	2	WS 100
609	678033119	Die Shoe Bolt Washer (Flat 5/8)	4	28-29
609A	643023009	Die Shoe Bolt Nut (Hex Full 5/8-11)	2	WS 1358
610	136122808	F 8 Punch Holder	1	58-14
611	633012131	Punch Holder Set Screw (SHSCP 5/16-18 x 3/4)	1	WS 615
612	136132828	F 28 Punch Holder	1	58-25
613	633012172	Punch Holder Set Screw (SHSCP 3/8-16 x 5/8)	1	WS 627
614	611012135	Punch Holder Cap Screw (SHC 5/16-18 x 1 1/4)	2	WS 526
615	731030265	Stripper Arm	2	
617	601012173	Stripper Arm Mounting Bolt (HHC 3/8-16 x 3/4)	2	WS 31
618	678033105	Stripper Arm Mounting Bolt Washer (Flat 3/8)	2	WS 1704
619	332200500	A-7 1/2" Stripper Plate	1	28-115-2
620	332201000	B-7 1" Stripper Plate	1	28-115-3
621	332202000	C-7 2" Stripper Plate	1	28-115-4
622	332203000	D-7 3" Stripper Plate	1	28-115-5
623	332204000	E-7 4" Stripper Plate	1	28-115-6
624	601012131	Stripper Plate Screw (HHC 5/16-18 x 3/4)	2	WS 16
625	678033104	Stripper Plate Screw Washer (Flat 5/16)	2	WS 1703
626	137000320	Work Table Assy. Complete	1	28-100
627	731090122	Work Table Plate	1	28-100-1
628	774420101	Work Table Gauge	3	241-5
629	611012084	Work Table Gauge & Screw (SHC 1/4-20 x 3/8)	7	WS 586
630	678033103	Work Table Gauge & Washer (Flat 1/4)	7	WS 1714
631	731200124	Work Table Clamp Bracket	2	28-100-3
632	731670123	Work Table Insert	1	28-100-2
633	605012131	Work Table & Clamp Brkt Screw (5/16-18 x 3/4)	4	WS 307
634	678033104	Work Table & Clamp Brkt Washer (Flat 5/16)	4	WS 1703
635	649023004	Work Table & Clamp Brkt Nut (5/16-18)	4	WS 1332