

Combination Rotary Machines

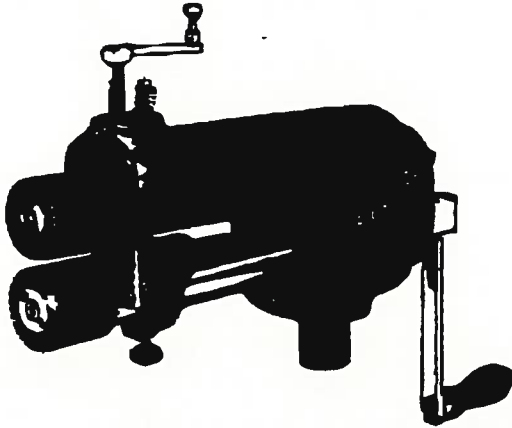

A combination Rotary Machine embodying all the features of the Throatless Machine with the added features of a 7" throat, and arbors designed to utilize crimping, beading, furnace collar edging and offset rolls.
See Roll Chart for rolls available.

MODEL	620	621	622
Capacity	24	24	24
Capacity crimping only			28
Depth of throat to frame	7	7	7
Distance between shaft centers ..	2	2	2
Shipping weight, boxed... approx. lbs.	48	48	50

INSTRUCTIONS

CAUTION ! Be certain that the machine is securely bolted into Bench Standard (23) and that Bench Standard is securely clamped to work bench. Also, work bench must be bolted to floor.

This machine may be used for Crimping, Beading, Furnace Collar Edging, Offsetting, Turning, Burring, Wiring, Elbow Edging, Flanging, Flattening and Slitting as needed. Crimping Rolls, Beading Rolls, Furnace Collar Rolls and Offset Rolls, when used, are mounted on the larger diameter of the Arbors (8 & 10), fitted snugly over the inner Roll Key Pins (11). All other Rolls are mounted on the smaller diameter of the Arbors, fitted snugly over the outer Roll Key Pins (11). Rolls are secured to Arbors with Roll Nuts (12).

1. The Hand Crank Assembly (22) provided with this machine is mounted on the Upper Arbor (8) for operations in Burring and Wiring.
2. Mount Crank Assembly (22) on Lower Arbor (10) for Crimping, Beading, Turning, etc.
3. Adjusting Screw (13), turned by rotating Adj. Screw Lever (14), is used to raise or lower the Front Upper Box (2) and Upper Arbor (8) with its Rolls, into and away from the work piece.
4. The Upper Arbor is laterally adjustable by backing off Set Screw (31) in Adjusting Nut (19) by turning the loosened Adjusting Nut (19) right or left in order to obtain alignment of Rolls. After Adjustment is made, tighten Set Screw (31) to secure Adjusting Nut (19).
5. Pivot Screws (7) for Rocking Box (4) are used to line up Crimping Rolls. To adjust Upper Crimping Roll, loosen Check Nuts (29) and turn Pivot Screws (7) toward or away from operator as necessary to align Crimping Rolls.
6. Secure Roll Nuts (12) with Spanner Wrench (21) before operating machine to prevent Roll slippage.
7. The Throat Gauge (3) can now be set to suit the work piece to the depth of the Horn (9) by loosening Thumb Screw (18) and moving Throat Gauge (3) to desired position and locking in place with Thumb Screw (18). (Throat Gauge is used alone for Beading only) See illustration.
8. End play in Lower Arbor (10) can be removed by loosening Set Screw (31) in Adjusting Nut (19) on Lower Arbor and turning Adjusting Nut (19) clockwise until all end play is removed. Tighten Set Screw (31) securely.
9. Keep machine Arbors, Screws, Rocking Box, Journal Bearings and Gears lubricated with a medium (SAE30) motor oil. Access to oil Gears may be found thru Gear Guard (5). "X" points should be lubricated daily with a good grade machine oil.

MODELS

No. 620 Beading Machine Is Furnished With:

- 11106 G Single Bead Roll
- 11107 G Single Bead Roll
- 10152 F Ogee Bead Roll
- 10153 F Ogee Bead Roll
- 10130 Throat Gauge
- 975 Bench Standard

No. 621 Furnace Collar Edger Is Furnished With:

- A51258 N Furnace Collar Edging Roll
- A51259 N Furnace Collar Edging Roll
- A51260 N Furnace Collar Edging Roll (2)
- BM7903 Extension Gauge
- 10130 Throat Gauge
- 975 Bench Standard

No. 622 Rotary Machine Is Furnished With:

- 10118 A Turning Roll
- 10119 A Turning Roll
- 10120 C Burring Roll
- 10121 C Burring Roll
- 10122 D Wiring Roll
- 10123 D Wiring Roll
- 10152 F Ogee Bead Roll
- 10153 F Ogee Bead Roll
- 10124 E Crimping Roll
- 10125 E Crimping Roll
- 10130 Throat Gauge
- Spec. 10126 Standard Gauge
- BM7903 Extension Gauge
- 975 Bench Standard

No. 622LR Rotary Machine Is Furnished With:

- 10130 Throat Gauge
- 975 Bench Standard



ROPER WHITNEY, INC.
2833 Huffman Blvd., Rockford, IL 61101
815/962-3011 TELEX: 25-7465



WHEN ORDERING REPLACEMENT PARTS, GIVE MODEL, LETTER,
AND SERIAL NUMBER SHOWN ON MACHINE NAMEPLATE, AND
PART DESCRIPTION SHOWN ON THE PARTS LIST.

PARTS LIST

Item No.	Part No.	Description	No. Req'd
1	764140001	Frame	1
2	764170002	Front Upper Box	1
3	259700093	Gauge	1
4	764170005	Rocking Box	1
5	590683880	Gear Guard	1
6	764010007	Crank Rod Holder	1
7	600010471	Pivot Screw	2
8	764680009	Upper Shaft	1
9	243700027	Horn Assembly	1
10	764680010	Shaft, Lower	1
11	600063498	Roll Pin for Shaft	4
12	764560011	Roll Nut	2
13	764670214	Adj. Screw	1
14	Included in Item 13	Adj. Screw Handle	1
15	664184537	Spring	1
16	764380013	Upper Conn. Gear	1
17	764380014	Lower Conn. Gear	1
18	764980004	Thumb Screw	1
19	764560015	Adj. Nut	2
20	664184536	Front Box Springs	1
21	764480016	Comb. Wrench	1
22	230700026	Crank Assembly, Hand	1
23	239009750	#975 Bench Standard. Complete	1
24	740570177	Plug	2
25	600123902	#3 Woodruff Key	2
26	609012101	1/4-20 x 2-1/2 Fil. Hd. Capscrew	1
27	678033103	1/4 Standard Washer	1
28	678033110	3/4 Standard Washer	1
29	649023006	7/16-14 Check Nut	2
30	621012132	5/16-18 x 7/8 oc. Setscrew	1
31	621012124	5/16-18 x 1/4 Soc. Setscrew	2
32	609012095	1/4-20 x 1-1/2 Rd. Hd. Screw	2
33	621012170	3/8-16 x 1/2 Soc. Setscrew	2
34	649023004	5/16-18 Jam Hex Nut	2
BS1	746060001	Standard	1
BS2	746010002	Swivel Cap	1
BS3	746030003	Lever for Clamping Screw	1
BS4	746650004	Clamping Screw	1
BS5	633012227	7/16-14 x 1-1/2 Sq. Hd. C.P.S.S.	1
BS6	640000111	3/16 x 2 Btn. Hd. Std. Rivet	1
BS7	600063443	5/32 x 3/4 Roll Pin	1

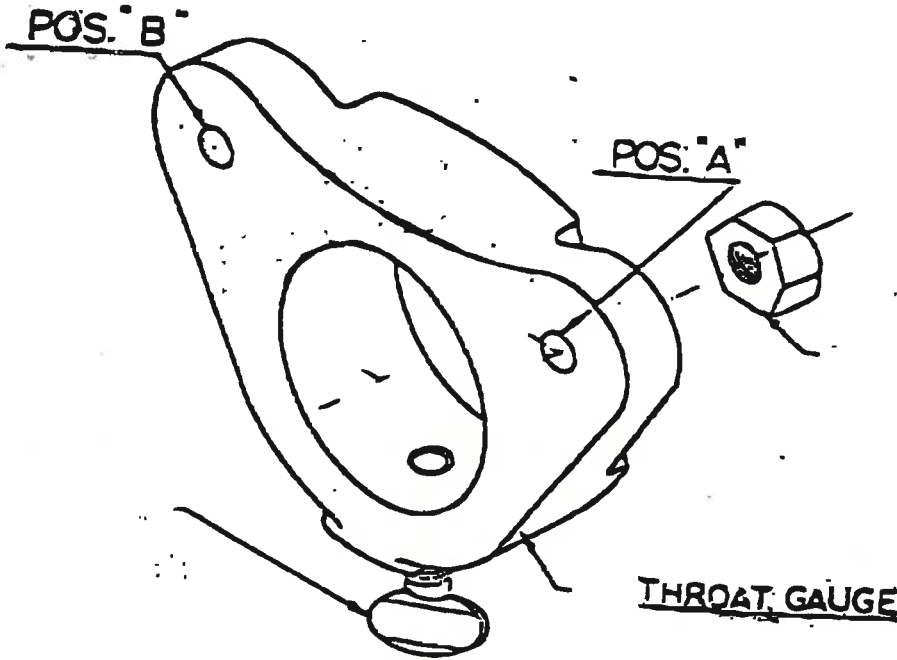

PART #
259700093

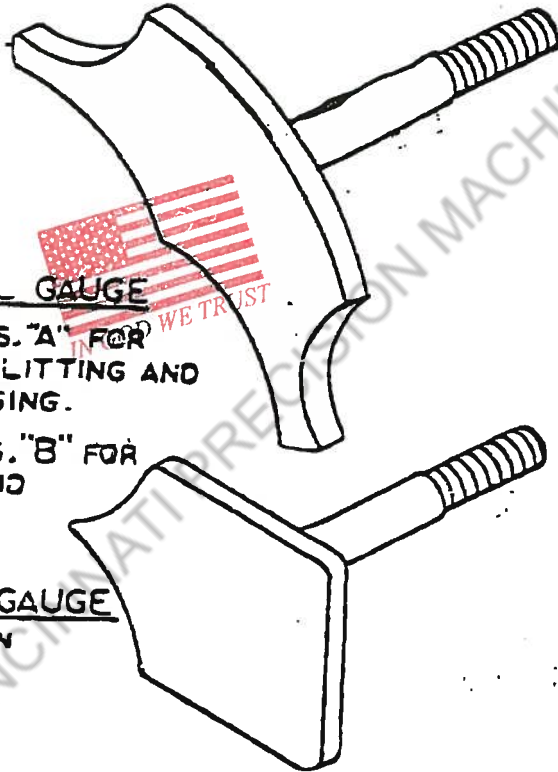

PART #
259700032

PART #
259700060

CINCINNATI PRECISION MACHINERY 513-860-4133

Combination Rotary Machines

ROLL CHART

NAME	ROLL NUMBER	CATALOG NUMBER	GAUGE REQ'D.	ROLL DIAGRAM
"A" Turning Roll 1/8"	10118 10119	350000001 350000002	10126	
"B" Turning Roll 3/16"	15037 15038	350000049 350000050	10126	
"C" Burring Roll	10120 10121	350000003 350000004	10126	
"D" Wiring Roll	10122 10123	350000005 350000006	10126	
No. 1 Elbow Edging Roll	15039 15040	350000051 350000052	10126	
"L" Flange Roll	15053 15054	350000053 350000054	Spec. 1541	
"M" Flat-tening Roll	15055 15056	350000055 350000056	None	

NAME	ROLL NUMBER	CATALOG NUMBER	GAUGE REQ'D.	ROLL DIAGRAM
"E" Crimping Roll	10124 10125	350000007 350000008	8M7903	
"F" Ogee Bead Roll 3/4"	10152 10153	350000009 350000010	10130	
"G" Single Bead Roll 1/4"	11106 11107	350000029 350000030	10130	
"H" Slitting Cutter Roll	SP2445 SP2446	350700068 350700069	10126	
"N" Furnace Collar Edging Roll	A51258 A51259 A51260 (2 Req'd)	350000067 350000068 350000069	8M7903	
"P" Offset Roll	A6512 A6513	350000076 350000077	8M7903	

We disclaim any responsibility whatsoever to the customer or to any other person for injury to person, or damage to or loss of property or value, caused by any product which has been subjected to misuse, negligence or accident; or misapplied; or modified or repaired by unauthorized persons; or improperly installed. We shall in no event be liable for any consequential damage, loss or expense arising from the use of or inability to use, our product.



ROPER WHITNEY, INC.
2833 Huffman Blvd., Rockford, IL. 61101
815/962-3011 TELEX: 25-7465

KH879

NOS. 620, 621, 622, 622LR COMBINATION ROTARY MACHINES

INSTRUCTIONS AND PARTS LIST

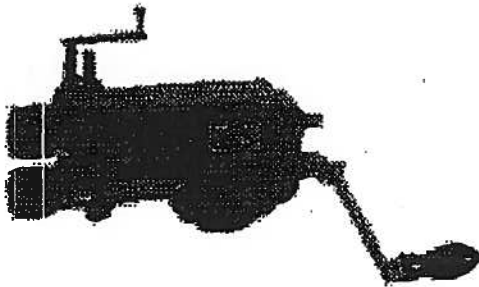

A combination Rotary Machine embodying all the features of the Throatless Machine with the added features of a 7" throat, and arbors designed to utilize crimping, beading, furnace collar edging and offset rolls.
See Roll Chart for rolls available.

MODEL	620	621	622
Capacity..... Gauge	24	24	24
Capacity Crimping Only..... Gauge			26
Depth of Throat to Frame.... Inches	7	7	7
Dist. Between Shaft Cntrs... Inches	2	2	2
Shipping Weight, Boxed..... Lbs. Approx.	48	48	50

MODELS

No. 620 Beading Machine is Furnished With:

350000029 G Single Bead Roll (11106)
350000030 G Single Bead Roll (11107)
350000009 F Ogee Bead Roll (10152)
350000010 F Ogee Bead Roll (10153)
259700093 Throat Gauge (10130)
975 Bench Standard

No. 621 Furnace Collar Edger is Furnished With:

350000067 N Furnace Collar Edging Roll (A51258)
350000068 N Furnace Collar Edging Roll (A51259)
350000069 N Furnace Collar Edging Roll (2) (A51260)
259700060 Extension Gauge (BM7903)
259700093 Throat Gauge (10130)
975 Bench Standard

No. 622 Rotary Machine is Furnished With:

350000001 A Turning Roll (10118)
350000002 A Turning Roll (10119)
350000003 C Burring Roll (10120)
350000004 C Burring Roll (10121)
350000005 D Wiring Roll (10122)
350000006 D Wiring Roll (10123)
350000009 F Ogee Bead Roll (10152)
350000010 F Ogee Bead Roll (10153)
350000007 E Crimping Roll (10124)
350000008 E Crimping Roll (10125)
259700093 Throat Gauge (10130)
259700032 Spec. Standard Gauge (10126)
259700060 Extension Gauge (BM7903)
975 Bench Standard

No. 622LR Rotary Machine is Furnished With:

259700093 Throat Gauge (10130)
975 Bench Standard



ROPER WHITNEY OF ROCKFORD, INC.

2833 HUFFMAN BLVD., ROCKFORD, ILLINOIS 61103-3990 * 815/962-3011 * FAX 815/962-2227

Website: www.roperswhitney.com * Email: info@roperswhitney.com

INSTRUCTIONS

CAUTION!

Be certain that the machine is securely bolted into Bench Standard (23) and that Bench Standard is securely clamped to work bench. Also, work bench must be bolted to floor.

This machine may be used for Crimping, Beading, Furnace Collar Edging, Offsetting, Turning, Burring, Wiring, Elbow Edging, Flanging, Flattening and Slitting as needed. Crimping Rolls, Beading Rolls, Furnace Collar Rolls and Offset Rolls, when used, are mounted on the larger diameter of the Arbors (8 & 10), fitted snugly over the inner Roll Key Pins (11). All other Rolls are mounted on the smaller diameter of the Arbors, fitted snugly over the outer Roll Key Pins (11). Rolls are secured to Arbors with Roll Nuts (12).

1. The Hand Crank Assembly (22) provided with this machine is mounted on the Upper Arbor (8) for operations in Burring and Wiring.
2. Mount Crank Assembly (22) on Lower Arbor (10) for Crimping, Beading, Turning, etc.
3. Adjusting Screw (13), turned by rotating Adjusting Screw Lever (14), is used to raise or lower the Front Upper Box (2) and Upper Arbor (8) with its Rolls, into and away from the work piece.
4. The Upper Arbor is laterally adjustable by backing off Set Screw (31) in Adjusting Nut (19) by turning the loosened Adjusting Nut (19) right or left in order to obtain alignment of Rolls. After adjustment is made, tighten Set Screw (31) to secure Adjusting Nut (19).
5. Pivot Screws (7) for Rocking Box (4) are used to line up Crimping Rolls. To adjust Upper Crimping Roll, loosen Check Nuts (29) and turn Pivot Screws (7) toward or away from operator as necessary to align Crimping Rolls.
6. Secure Roll Nuts (12) with Spanner Wrench (21) before operating machine to prevent Roll slippage.
7. The Throat Gauge (3) can now be set to suit the work piece to the depth of the Horn (9) by loosening Thumb Screw (18) and moving Throat Gauge (3) to desired position and locking in place with Thumb Screw (18). The Throat Gauge is used alone for Beading only, see illustration.
8. End play in Lower Arbor (10) can be removed by loosening Set Screw (31) in Adjusting Nut (19) on Lower Arbor and turning Adjusting Nut (19) clockwise until all end play is removed. Tighten Set Screw (31) securely.
9. Keep machine Arbors, Screws, Rocking Box, Journal Bearings and Gears lubricated with a medium (SAE30) motor oil. Access to oil Gears may be found through Gear Guard (5). "X" points should be lubricated daily with a good grade machine oil.

MODELS 620, 621, 622, 622LR PARTS IDENTIFICATION CHART

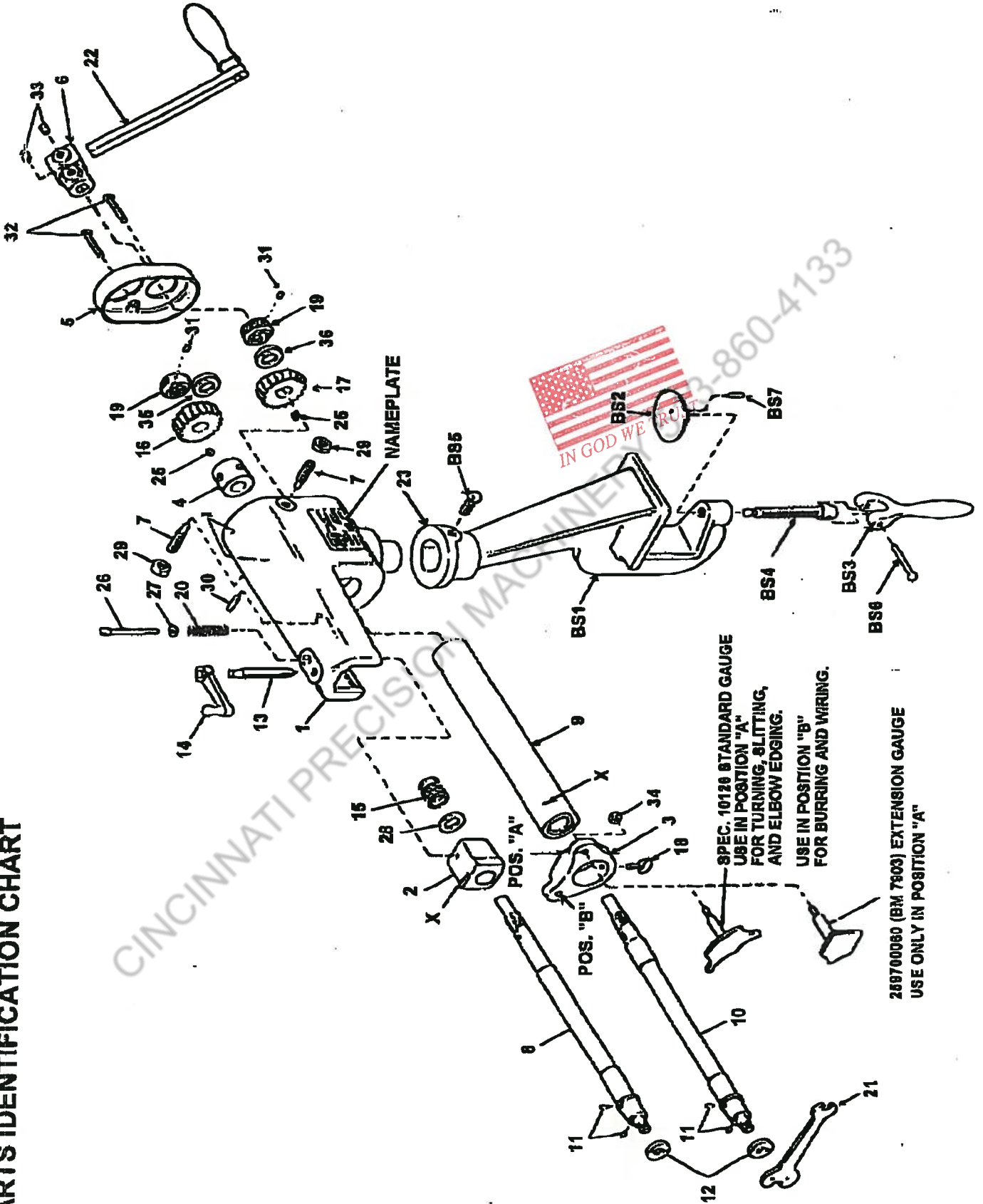

CINCINNATI PRECISION MACHINERY 313-860-4133

MODELS 620, 621, 622, 622LR GAUGE IDENTIFICATION CHART

Distributed By:
CINCINNATI Precision Machinery
 3050 Sinton Place
 Hamilton, OH 45011
 For Parts, Tooling or Customer Service
 Call 1-888-860-4133
 Fax
 Phone No. 513-860-4133

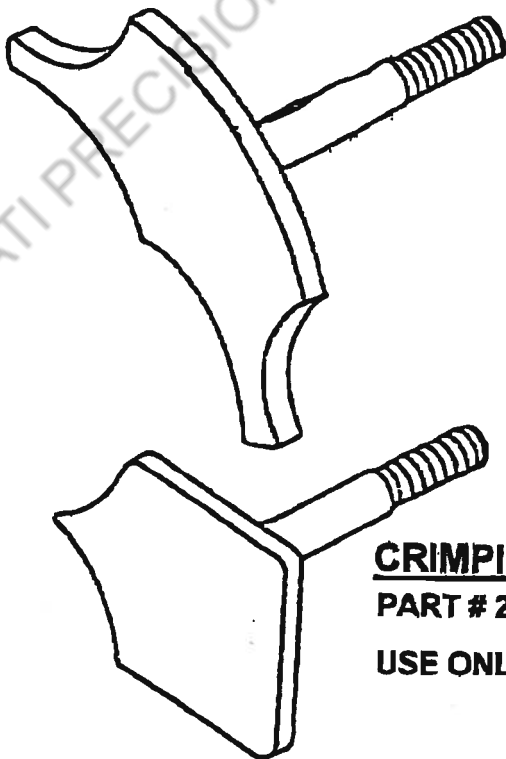
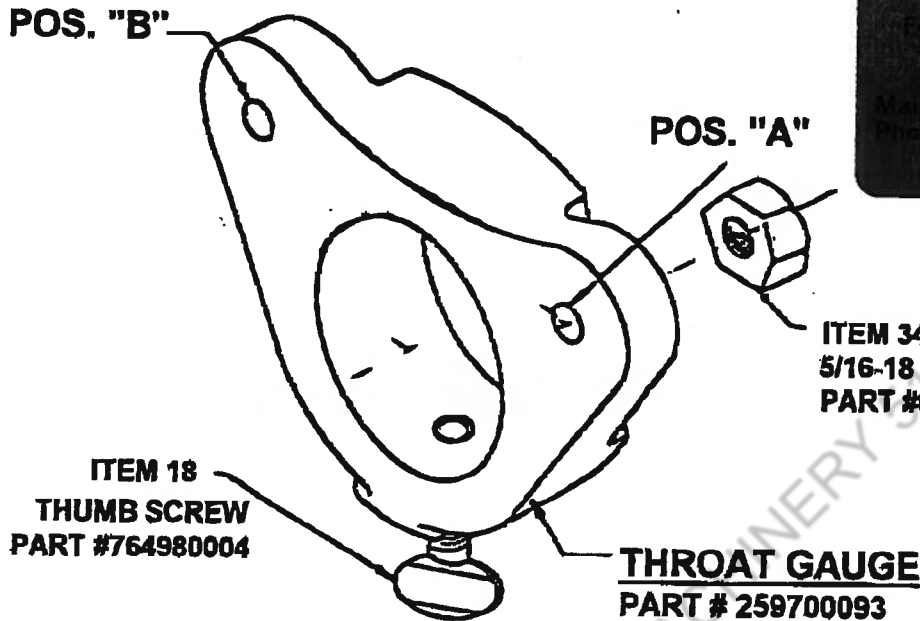

UNIVERSAL GAUGE

PART # 259700032

USE IN POS. "A" FOR
TURNING - SLITTING AND
ELBOW EDGING.

USE IN POS. "B" FOR
BURRING AND WIRING

CRIMPING GAUGE

PART # 259700060

USE ONLY IN "A"





CINCINNATI PRECISION MACHINERY 1-860-4133

MODELS 620, 621, 622, 622LR PARTS LIST

ITEM NO.	PART NO.	DESCRIPTION	QTY.
1	764140001	Frame	1
2	764170002	Front Upper Box	1
3	259700093	Gauge	1
4	764170005	Rocking Box	1
5	590683880	Gear Guard	1
6	764010007	Crank Rod Holder	1
7	600010471	Pivot Screw	2
8	764680009	Upper Shaft	1
9	243700027	Horn Assembly	1
10	764680010	Lower Shaft	1
11	600063498	Roll Pin for Shaft	4
12	764560011	Roll Nut	2
13	764670214	Adjusting Screw	1
14	Included in Item 13	Adjusting Screw Handle	1
15	664184537	Spring	1
16	764380013	Upper Connecting Gear	1
17	764380014	Lower Connecting Gear	1
18	764980004	Thumb Screw	1
19	764560015	Adjusting Nut	2
20	664184536	Front Box Springs	1
21	764480016	Comb. Wrench	1
22	230700026	Hand Crank Assembly	1
23	239009750	#975 Bench Standard Complete	1
25	600123902	#3 Woodruff Key	2
26	609012101	RHM Screw 1/4-20 x 2 1/2	1
27	678033103	Flat Washer 1/4	1
28	678033110	Flat Washer 3/4	1
29	649023006	Hex Jam Nut 7/16-14	2
30	621012132	SSCP Screw 5/16-18 x 7/8	1
31	600010461	Brass Tip Set Screw 5/16-18 x 1/4	2
32	609012095	RHM Screw 1/4-20 x 1 1/2	2
33	621012170	SSCP Screw 3/8-16 x 1/2	2
34	649023004	Jam Hex Nut 5/16-18	2
35	764830225	Upper Spacer	1
36	764830226	Lower Spacer	1
BS1	746060001	Standard	1
BS2	746010002	Swivel Cap	1
BS3	746030003	Lever for Clamping Screw	1
BS4	746650004	Clamping Screw	1
BS5	633012227	SHSCP Screw 7/16-14 x 1 1/2	1
BS6	600063472	Roll Pin 1/4 Dia. x 1 3/4	1
BS7	600063442	Roll Pin 5/32 Dia. x 11/16	1



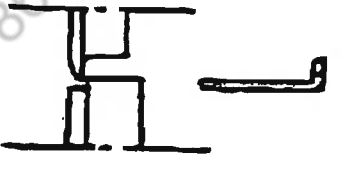
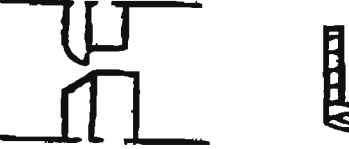

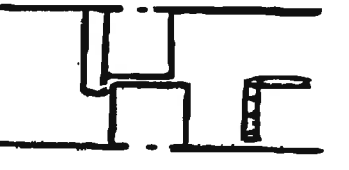
When ordering replacement parts, give model, letter, and serial number shown on machine nameplate, and part description shown on the parts list.

MODELS 620, 621, 622, 622LR ROLL CHART

NAME	OLD ROLL NUMBER	CATALOG NUMBER	GAUGE REQ'D	ROLL DIAGRAM
"A" Turning Roll 1/8"	10118 10119	350000001 350000002	259700032 (10126)	
"B" Turning Roll 3/16"	15037 15038	350000049 350000050	259700032 (10126)	
"C" Burring Roll	10120 10121	350000003 350000004	259700032 (10126)	
"D" Wiring Roll	10122 10123	350000005 350000006	259700032 (10126)	
No. 1 Elbow Edging Roll	15039 15040	350000051 350000052	259700032 (10126)	
"L" Flange Roll	15053 15054	350000053 350000054	259700045 (Spec. 1541)	
"M" Flattening Roll	15055 15056	350000055 350000056	None	

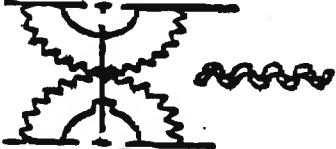
We disclaim any responsibility whatsoever to the customer or to any other person for injury to person, or damage to or loss of property or value, caused by any product which has been subjected to misuse, negligence or accident; or misapplied; or modified or repaired by unauthorized persons; or improperly installed. We shall in no event be liable for any consequential damage, loss or expense arising from the use of or inability to use, our product.

MODELS 620, 621, 622, 622LR ROLL CHART

NAME	OLD ROLL NUMBER	CATALOG NUMBER	GAUGE REQ'D	ROLL DIAGRAM
"E" Crimping Roll	10124 10125	350000007 350000008	259700060 (BM7903)	
"F" Ogee Bead Roll 3/4"	10152 10153	350000009 350000010	259700093 (10130)	
"G" Single Bead Roll 1/4"	11106 11107	350000029 350000030	259700093 (10130)	
"H" Slitting Cutter Roll	SP2445 SP2446	350700068 350700069	259700032 (10126)	
"N" Furnace Collar Edging Roll	A51258 A51259 A51260 (2 Req'd)	350000067 350000068 350000069	259700060 (BM7903)	
"P" Offset Roll	A6512 A6513	350000076 350000077	259700060 (BM7903)	