

HBU48-16 and S48-16

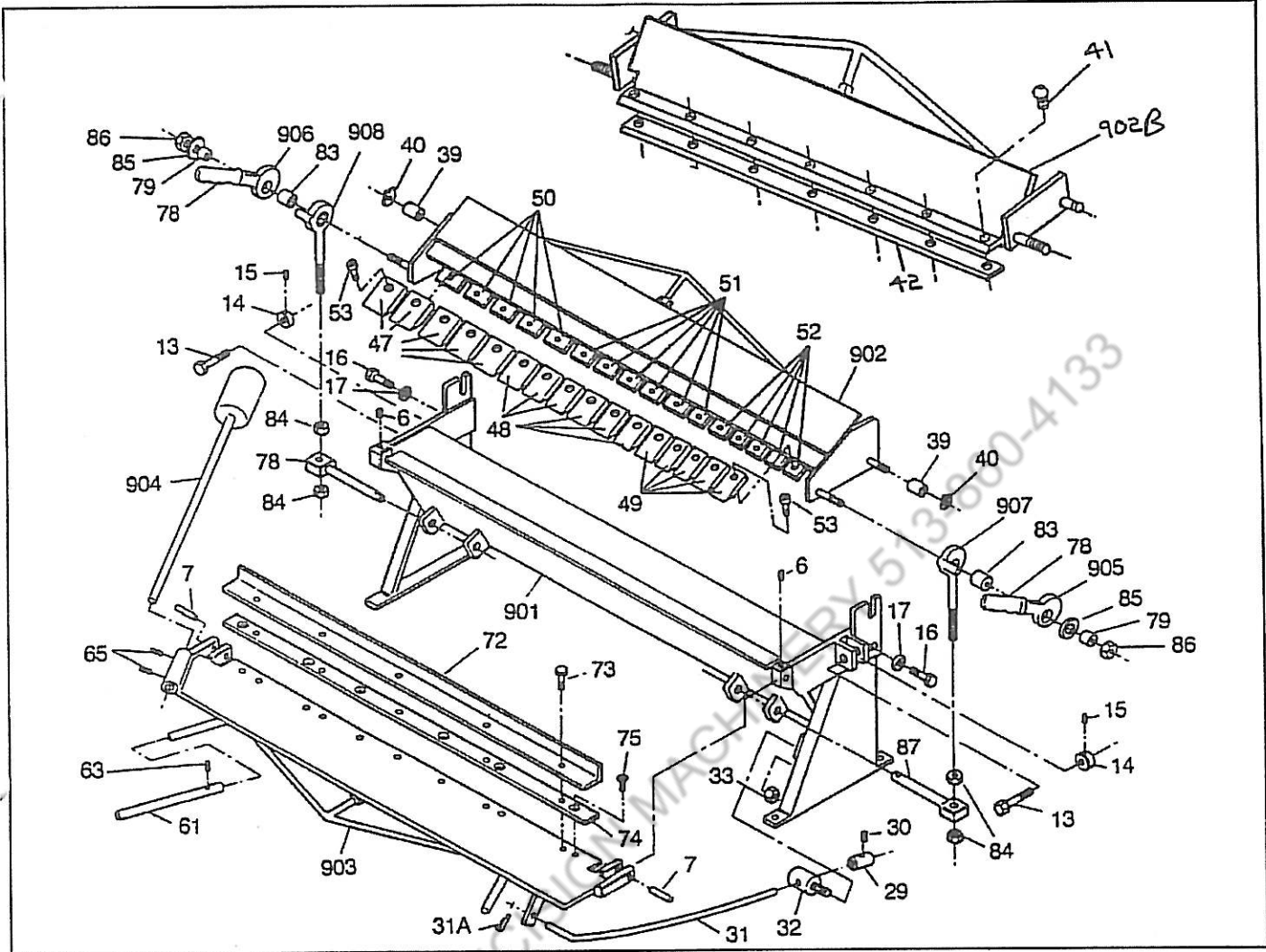

PART NO.	DESCRIPTION	NO. REQ'D.	PART NO.	DESCRIPTION	NO. REQ'D.
U48-16-901	BASE ASS'Y.	1	U48-16-50	4" FINGER CLAMP	5
U48-16-6	SET SCREW HINGE BRKT.	2	U48-16-51	3" FINGER CLAMP	6
U48-16-7	PIN HINGE	2	U48-16-52	2" FINGER CLAMP	5
U48-16-13	SCREW BRKT. ADJ.	2	U48-16-53	SCREW, CLAMP	16
U48-16-14	NUT, ADJ. BRKT.	2	U48-16-903	APRON ASS'Y.	1
U48-16-15	SET SCREW, ADJ. NUT	2	U48-16-61	HANDLE EXTENSION	2
U48-16-16	SCREW, BRKT. LOCK	2	U48-16-63	SET SCREW, EXT.	2
U48-16-17	WASHER, LOCK SCREW	2	U48-16-65	SET SCREW, HOLDER	2
U48-16-29	STOP	1	U48-16-904	C'WEIGHT ASS'Y.	1
U48-16-30	SET SCREW, STOP	1	U48-16-72	SUPPORT ANGLE	1
U48-16-31	STOP ROD	1	U48-16-73	SCREW, ANGLE	5
U48-16-31A	KEY, ROD	1	U48-16-74	INSERT	1
U48-16-32	STOP, SWIVEL	1	U48-16-75	SCREW, INSERT	8
U48-16-33	NUT, SWIVEL	1	U48-16-905	R.H. CLAMP HANDLE ASS'Y.	1
U48-16-902	HOLDDOWN ASS'Y.	1	U48-16-906	L.H. CLAMP HANDLE ASS'Y.	1
S48-16-902B	HOLDDOWN ASS'Y.	1	U48-16-78	HANDGRIP	2
U48-16-39	BUSHING PIN	2	U48-16-79	BUSHING, CAM	2
U48-16-40	RETAINER RING	2	U48-16-907	R.H. YOKE ASS'Y.	1
S48-16-41	SCREW, INSERT	7	U48-16-908	L.H. YOKE ASS'Y.	1
S48-16-42	INSERT, HOLDDOWN	1	U48-16-83	BUSHING, YOKE	2
U48-16-47	4" FINGER	5	U48-16-84	NUT, YOKE ADJ.	4
U48-16-48	3" FINGER	6	U48-16-85	WASHER, CLAMP	2
U48-16-49	2" FINGER	5	U48-16-86	NUT, CLAMP	2
			U48-16-87	SWIVEL, CLAMP	2