

The Slip-on flange Watson

Fasten Slip-on flange to ductwork - Quick

No more painful Rivets, Nails, and Screws.

Join the Green Clinching Revolution.



Advantages:

- No Consumables
- Clean Operation
- Safe Handling Parts for Operators and Installers
- Air powered
- Consistent Connections
- Clinch up to 3-ply 18g
- Fastens Easy to Clean Ductwork.
- Stainless Steel Capable

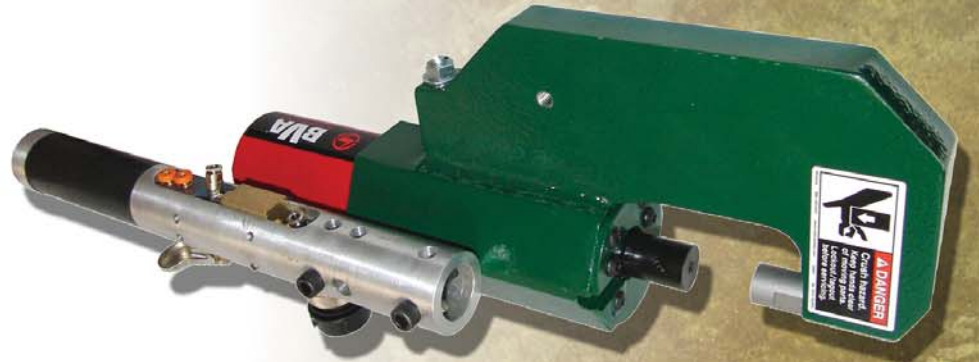

The Slip-on flange Watson

Technical Data:

Workhead weight:	19 lbs (8.6 kg)
Total weight, inc. Booster:	90 lbs (41 kg)
Working air pressure:	80 psi (5.4 Bar)
Hydraulic pressure at 6 bar:	4,400 psi (299 Bar)
Cycle Time:	1.0-2.0 s
Max thickness, mild steel:	0.150" (3.8mm)
Max thickness, stainless steel:	0.100" (2.5mm)
Power Requirement (Option):	50/60 Hz
	100v - 240v (0.9a)

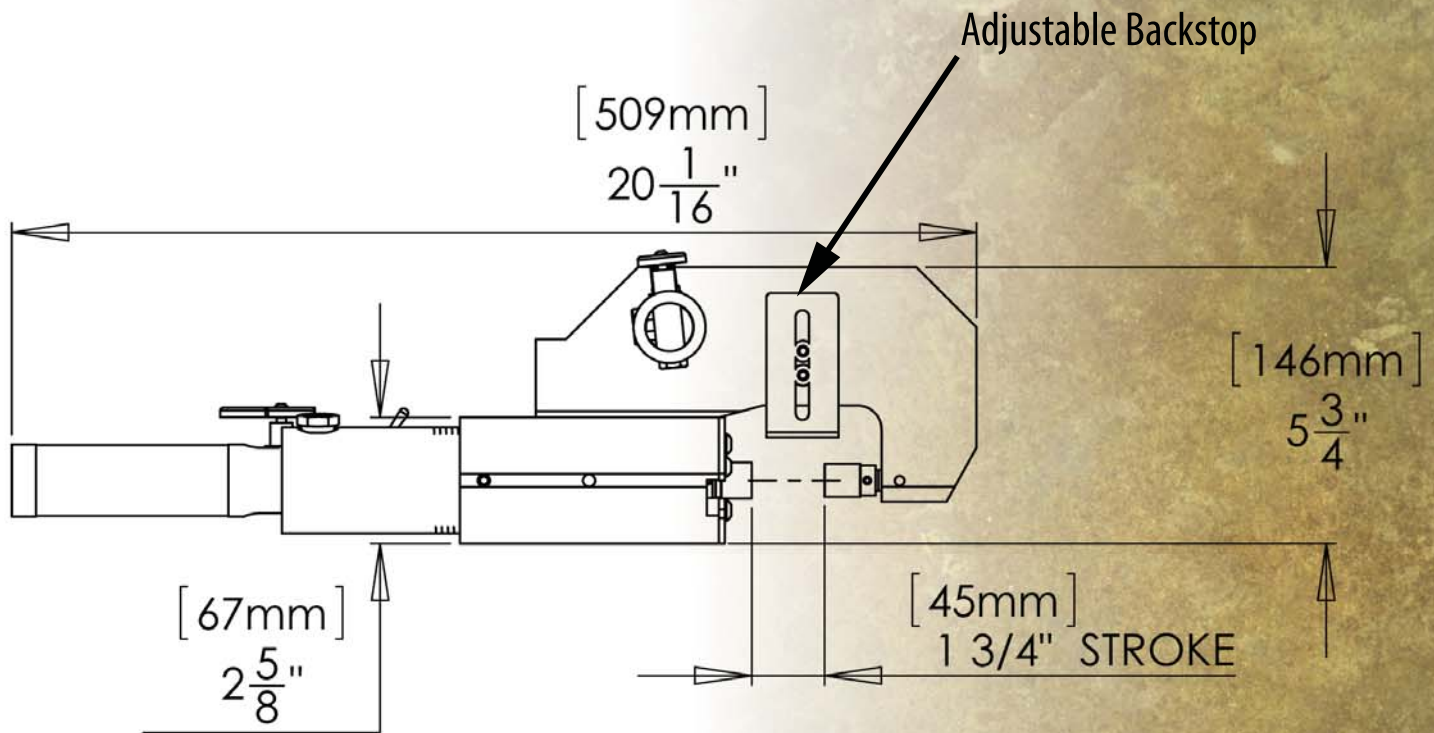
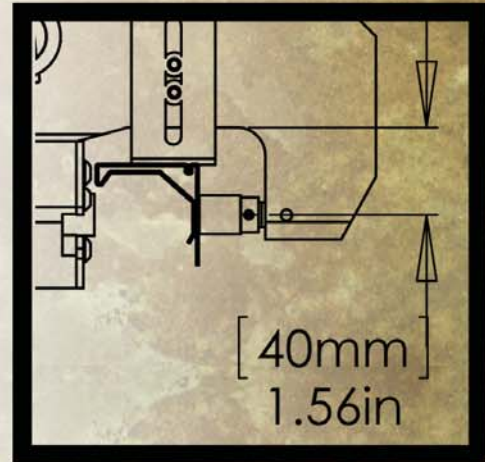

26 Adams Boulevard, Brantford, Ontario, Canada N3S 7V2
519.759.5896 Fax: 519.759.2948
Email: info@norlok.com Web: www.norlok.com

DISTRIBUTED BY

CINCINNATI Precision Machinery, Inc.
www.cpmfab.com
513-860-4133